

# Dual Monostable Multivibrator

The MC14528B is a dual, retriggerable, resettable monostable multivibrator. It may be triggered from either edge of an input pulse, and produces an output pulse over a wide range of widths, the duration of which is determined by the external timing components,  $C_X$  and  $R_X$ .

- Separate Reset Available
- Diode Protection on All Inputs
- Triggerable from Leading or Trailing Edge Pulse
- Supply Voltage Range = 3.0 Vdc to 18 Vdc
- Capable of Driving Two Low-power TTL Loads or One Low-power Schottky TTL Load Over the Rated Temperature Range
- Pin-for-Pin Replacement with the MC14538B

**MAXIMUM RATINGS\*** (Voltages Referenced to  $V_{SS}$ )

Symbol	Parameter	Value	Unit
$V_{DD}$	DC Supply Voltage	- 0.5 to + 18.0	V
$V_{in}, V_{out}$	Input or Output Voltage (DC or Transient)	- 0.5 to $V_{DD} + 0.5$	V
$I_{in}, I_{out}$	Input or Output Current (DC or Transient), per Pin	$\pm 10$	mA
$P_D$	Power Dissipation, per Package†	500	mW
$T_{stg}$	Storage Temperature	- 65 to + 150	°C
$T_L$	Lead Temperature (8-Second Soldering)	260	°C

\* Maximum Ratings are those values beyond which damage to the device may occur.

† Temperature Derating:

Plastic "P and D/DW" Packages: - 7.0 mW/°C From 65°C To 125°C  
Ceramic "L" Packages: - 12 mW/°C From 100°C To 125°C

**ONE-SHOT SELECTION GUIDE**

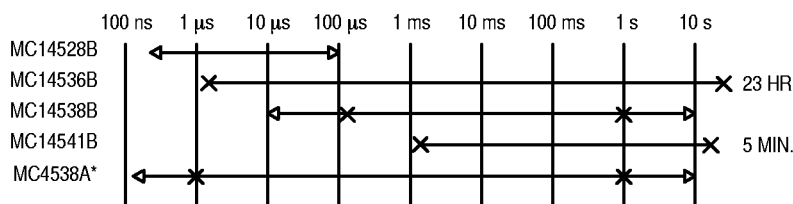

\*LIMITED OPERATING VOLTAGE (2-6 V)

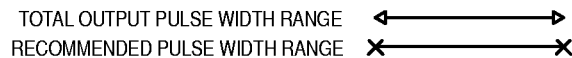

## MC14528B

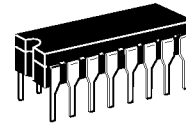

**L SUFFIX**  
CERAMIC  
CASE 620

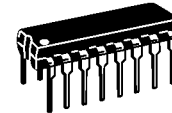

**P SUFFIX**  
PLASTIC  
CASE 648



**D SUFFIX**  
SOIC  
CASE 751B

**ORDERING INFORMATION**

MC14XXXBCP Plastic  
MC14XXXBCL Ceramic  
MC14XXXBD SOIC  
 $T_A = -55^\circ$  to  $125^\circ\text{C}$  for all packages.

**BLOCK DIAGRAM**

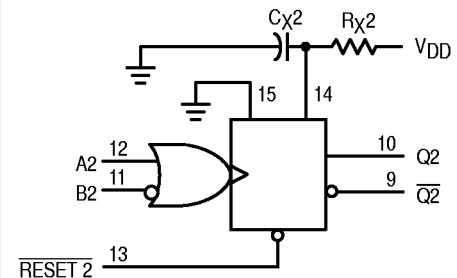
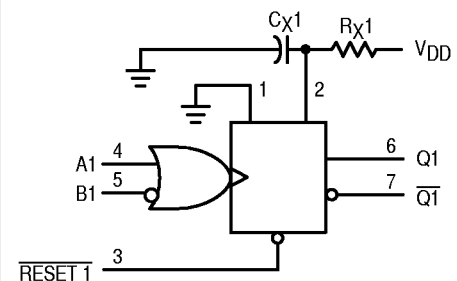

$V_{DD}$  = PIN 16  
 $V_{SS}$  = PIN 1, PIN 8, PIN 15  
 $R_X$  AND  $C_X$  ARE EXTERNAL COMPONENTS

**ELECTRICAL CHARACTERISTICS** (Voltages Referenced to V<sub>SS</sub>)

Characteristic	Symbol	V <sub>DD</sub> Vdc	- 55°C		25°C			125°C		Unit	
			Min	Max	Min	Typ #	Max	Min	Max		
Output Voltage V <sub>in</sub> = V <sub>DD</sub> or 0	"0" Level V <sub>OL</sub>	5.0	—	0.05	—	0	0.05	—	0.05	Vdc	
		10	—	0.05	—	0	0.05	—	0.05		
		15	—	0.05	—	0	0.05	—	0.05		
	"1" Level V <sub>in</sub> = 0 or V <sub>DD</sub>	V <sub>OH</sub>	5.0	4.95	—	4.95	5.0	—	4.95	—	Vdc
			10	9.95	—	9.95	10	—	9.95	—	
			15	14.95	—	14.95	15	—	14.95	—	
Input Voltage (V <sub>O</sub> = 4.5 or 0.5 Vdc) (V <sub>O</sub> = 9.0 or 1.0 Vdc) (V <sub>O</sub> = 13.5 or 1.5 Vdc)	"0" Level V <sub>IL</sub>	5.0	—	1.5	—	2.25	1.5	—	1.5	Vdc	
		10	—	3.0	—	4.50	3.0	—	3.0		
		15	—	4.0	—	6.75	4.0	—	4.0		
	"1" Level (V <sub>O</sub> = 0.5 or 4.5 Vdc) (V <sub>O</sub> = 1.0 or 9.0 Vdc) (V <sub>O</sub> = 1.5 or 13.5 Vdc)	V <sub>IH</sub>	5.0	3.5	—	3.5	2.75	—	3.5	—	Vdc
			10	7.0	—	7.0	5.50	—	7.0	—	
			15	11	—	11	8.25	—	11	—	
Output Drive Current (V <sub>OH</sub> = 2.5 Vdc) (V <sub>OH</sub> = 4.6 Vdc) (V <sub>OH</sub> = 9.5 Vdc) (V <sub>OH</sub> = 13.5 Vdc)	Source I <sub>OH</sub>	5.0	-1.2	—	-1.0	-1.7	—	-0.7	—	mAdc	
		5.0	-0.64	—	-0.51	-0.88	—	-0.36	—		
		10	-1.6	—	-1.3	-2.25	—	-0.9	—		
	Sink I <sub>OL</sub>	5.0	0.64	—	0.51	0.88	—	0.36	—	mAdc	
		10	1.6	—	1.3	2.25	—	0.9	—		
		15	4.2	—	3.4	8.8	—	2.4	—		
Input Current	I <sub>in</sub>	15	—	± 0.1	—	±0.00001	± 0.1	—	± 1.0	μAdc	
Input Capacitance (V <sub>in</sub> = 0)	C <sub>in</sub>	—	—	—	—	5.0	7.5	—	—	pF	
Quiescent Current (Per Package)	I <sub>DD</sub>	5.0	—	5.0	—	0.005	5.0	—	150	μAdc	
		10	—	10	—	0.010	10	—	300		
		15	—	20	—	0.015	20	—	600		
**Total Supply Current at an external load Capacitance (C <sub>L</sub> ) and at external timing capacitance (C <sub>X</sub> ), use the formula —	I <sub>T</sub>	—	$I_T(C_L, C_X) = [(C_L + 0.36C_X)V_{DD}f + 2 \times 10^{-8} R_X C_X (V_{DD} - 2)^2 f] \times 10^{-3}$ where: I <sub>T</sub> in μA (per circuit), C <sub>L</sub> and C <sub>X</sub> in pF, R <sub>X</sub> in megohms, V <sub>DD</sub> in Vdc, f in kHz is input frequency.							μAdc	

#Data labelled "Typ" is not to be used for design purposes but is intended as an indication of the IC's potential performance.

\*\* The formulas given are for the typical characteristics only at 25°C.

This device contains protection circuitry to guard against damage due to high static voltages or electric fields. However, precautions must be taken to avoid applications of any voltage higher than maximum rated voltages to this high-impedance circuit. For proper operation, V<sub>in</sub> and V<sub>out</sub> should be constrained to the range V<sub>SS</sub> ≤ (V<sub>in</sub> or V<sub>out</sub>) ≤ V<sub>DD</sub>. Unused inputs must always be tied to an appropriate logic voltage level (e.g., either V<sub>SS</sub> or V<sub>DD</sub>). Unused outputs must be left open.

**PIN ASSIGNMENT**

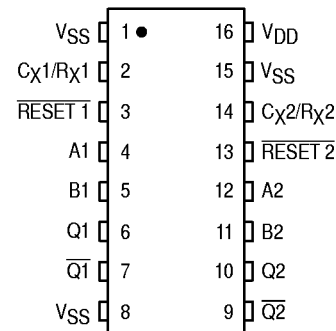

**SWITCHING CHARACTERISTICS\*\*** ( $C_L = 50 \text{ pF}$ ,  $T_A = 25^\circ\text{C}$ )

Characteristic	Symbol	$C_X$ pF	$R_X$ k $\Omega$	$V_{DD}$ Vdc	Min	Typ #	Max	Unit
Output Rise and Fall Time $t_{TLH}, t_{THL} = (1.5 \text{ ns/pF}) C_L + 25 \text{ ns}$ $t_{TLH}, t_{THL} = (0.75 \text{ ns/pF}) C_L + 12.5 \text{ ns}$ $t_{TLH}, t_{THL} = (0.55 \text{ ns/pF}) C_L + 9.5 \text{ ns}$	$t_{TLH},$ $t_{THL}$	—	—	5.0 10 15	— — —	100 50 40	200 100 80	ns
Turn-Off, Turn-On Delay Time — A or B to Q or $\bar{Q}$ $t_{PLH}, t_{PHL} = (1.7 \text{ ns/pF}) C_L + 240 \text{ ns}$ $t_{PLH}, t_{PHL} = (0.66 \text{ ns/pF}) C_L + 87 \text{ ns}$ $t_{PLH}, t_{PHL} = (0.5 \text{ ns/pF}) C_L + 65 \text{ ns}$	$t_{PLH},$ $t_{PHL}$	15	5.0	5.0 10 15	— — —	325 120 90	650 240 180	ns
Turn-Off, Turn-On Delay Time — A or B to Q or $\bar{Q}$ $t_{PLH}, t_{PHL} = (1.7 \text{ ns/pF}) C_L + 620 \text{ ns}$ $t_{PLH}, t_{PHL} = (0.66 \text{ ns/pF}) C_L + 257 \text{ ns}$ $t_{PLH}, t_{PHL} = (0.5 \text{ ns/pF}) C_L + 185 \text{ ns}$	$t_{PLH},$ $t_{PHL}$	1000	10	5.0 10 15	— — —	705 290 210	— — —	ns
Input Pulse Width — A or B	$t_{WH}$	15	5.0	5.0	150	70	—	ns
				10	75	30	—	ns
	$t_{WL}$	1000	10	5.0 10 15	— — —	70 30 30	— — —	ns
Output Pulse Width — Q or $\bar{Q}$ (For $C_X < 0.01 \mu\text{F}$ use graph for appropriate $V_{DD}$ level.)	$t_W$	15	5.0	5.0 10 15	— — —	550 350 300	— — —	ns
Output Pulse Width — Q or $\bar{Q}$ (For $C_X > 0.01 \mu\text{F}$ use formula: $t_W = 0.2 R_X C_X \ln [V_{DD} - V_{SS}]^\dagger$ )	$t_W$	10,000	10	5.0 10 15	15 10 15	30 50 55	45 90 95	$\mu\text{s}$
Pulse Width Match between Circuits in the same package	$t_1 - t_2$	10,000	10	5.0 10 15	— — —	6.0 8.0 8.0	25 35 35	%
Reset Propagation Delay — $\overline{\text{Reset}}$ to Q or $\bar{Q}$	$t_{PLH},$ $t_{PHL}$	15	5.0	5.0	—	325	600	ns
				10	—	90	225	ns
		1000	10	5.0 10 15	— — —	1000 300 250	— — —	ns
Retrigger Time	$t_{rr}$	15	5.0	5.0	0	—	—	ns
				10	0	—	—	ns
		1000	10	5.0 10 15	0 0 0	— — —	— — —	ns
External Timing Resistance	$R_X$	—	—	—	5.0	—	1000	k $\Omega$
External Timing Capacitance	$C_X$	—	—	—	No Limits*			$\mu\text{F}$

$\dagger R_X$  is in Ohms,  $C_X$  is in farads,  $V_{DD}$  and  $V_{SS}$  in volts,  $PW_{out}$  in seconds.

\* If  $C_X > 15 \mu\text{F}$ , Use Discharge Protection Diode  $D_X$ , per Fig. 9.

\*\* The formulas given are for the typical characteristics only at  $25^\circ\text{C}$ .

#Data labelled "Typ" is not to be used for design purposes but is intended as an indication of the IC's potential performance.

**FUNCTION TABLE**

Inputs			Outputs	
$\overline{\text{Reset}}$	A	B	Q	$\bar{Q}$
H		H		
H	L			
H		L	Not Triggered	Not Triggered
H	H		Not Triggered	Not Triggered
H	L, H,	H	Not Triggered	Not Triggered
H	L	L, H,	Not Triggered	Not Triggered
L	X	X	L	H
	X	X	Not Triggered	Not Triggered

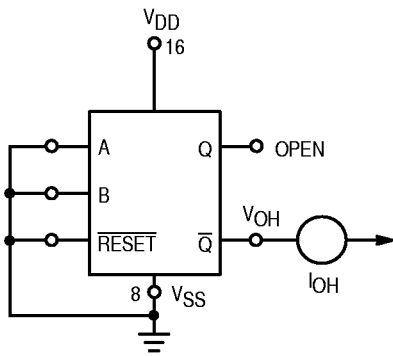

Figure 1. Output Source Current Test Circuit

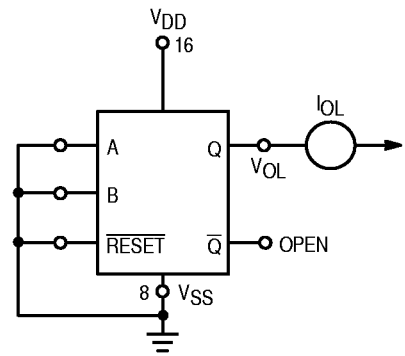

Figure 2. Output Sink Current Test Circuit

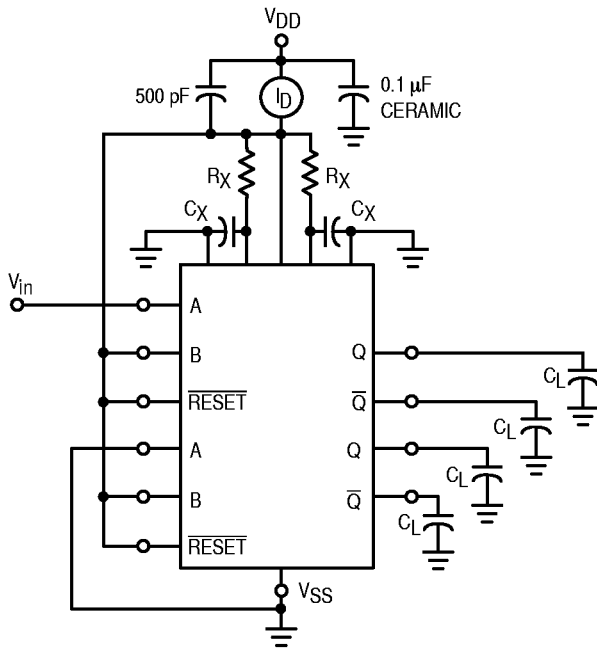

Figure 3. Power Dissipation Test Circuit and Waveforms

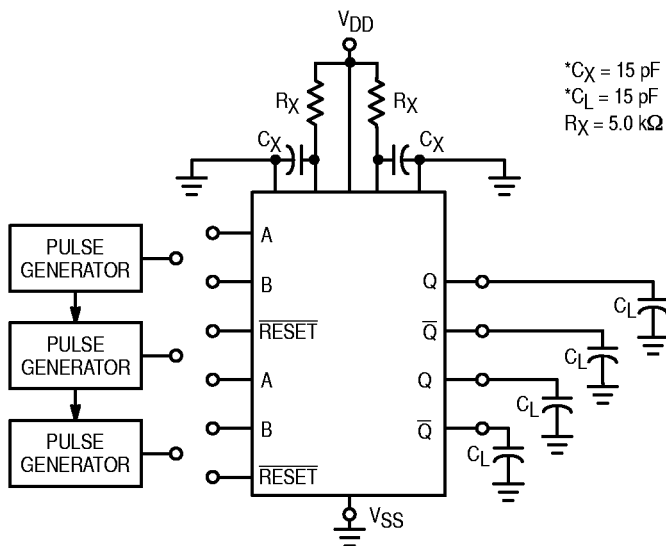
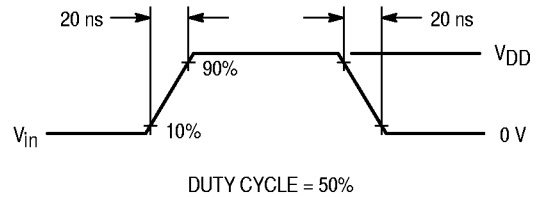

Figure 4. AC Test Circuit



INPUT CONNECTIONS

Characteristics	Reset	A	B
$t_{PLH}$ , $t_{PHL}$ , $t_{TLH}$ , $t_{THL}$ $t_W$	V <sub>DD</sub>	PG1	V <sub>DD</sub>
$t_{PLH}$ , $t_{PHL}$ , $t_{TLH}$ , $t_{THL}$ $t_W$	V <sub>DD</sub>	V <sub>SS</sub>	PG2
$t_{PLH(R)}$ , $t_{PHL(R)}$ , $t_W$	PG3	PG1	PG2

\* Includes capacitance of probes, wiring, and fixture parasitic.

NOTE: AC test waveforms for PG1, PG2, and PG3 on next page.

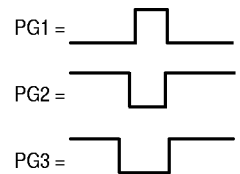

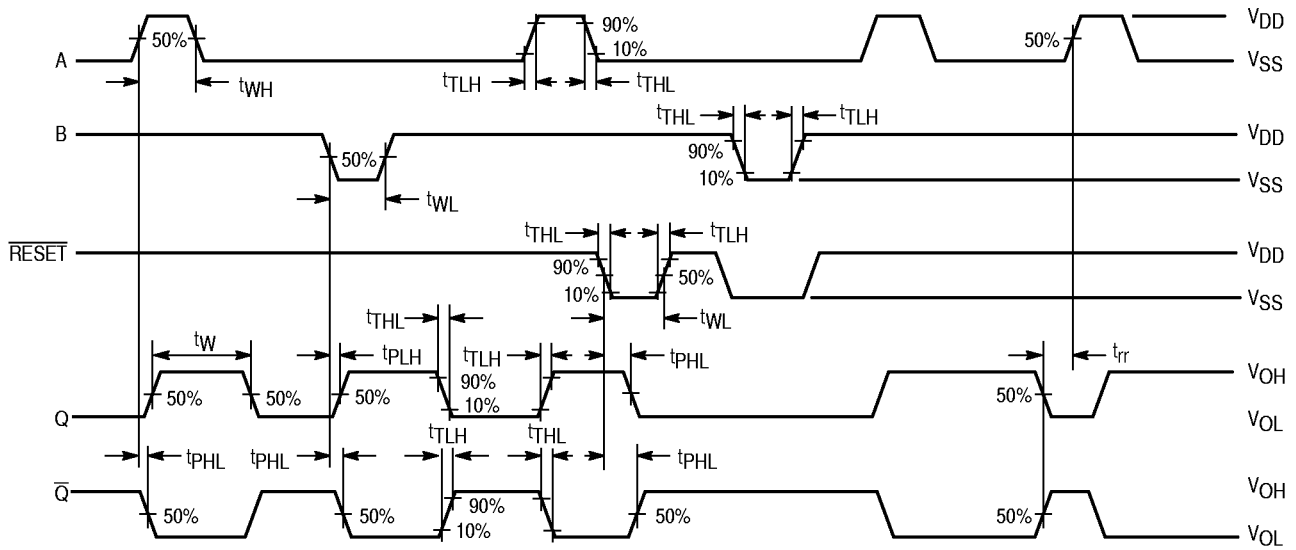

Figure 5. AC Test Waveforms

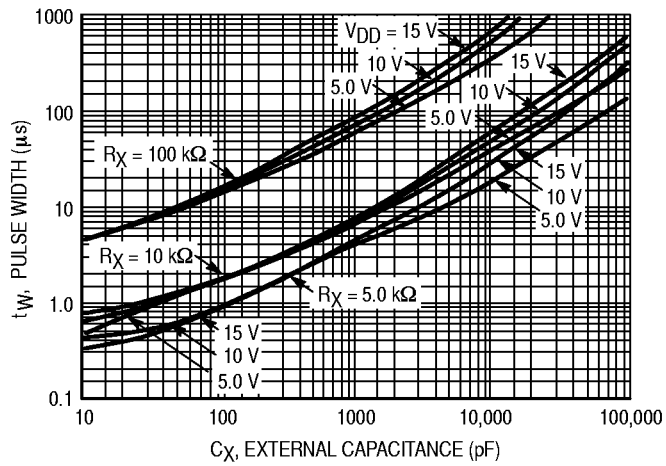
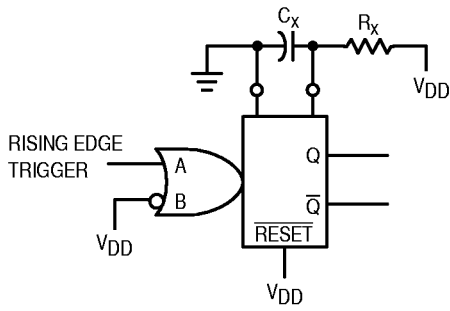
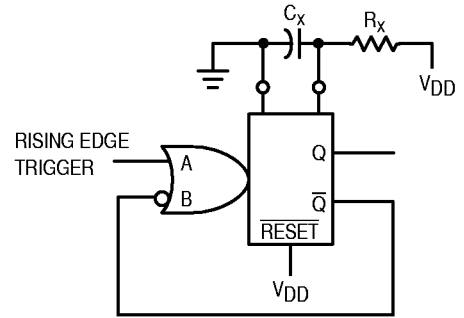
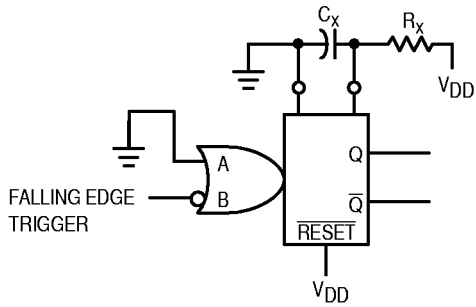

Figure 6. Pulse Width versus  $C_X$

## TYPICAL APPLICATIONS



**Figure 7. Retriggerable Monostables Circuitry**



**Figure 8. Non-Retriggerable Monostables Circuitry**

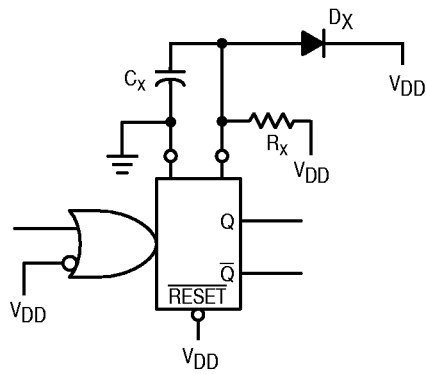
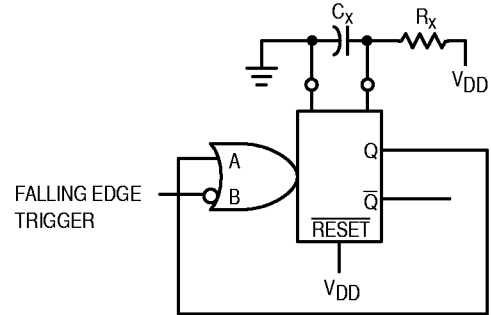

**Figure 9. Use of a Diode to Limit Power Down Current Surge**

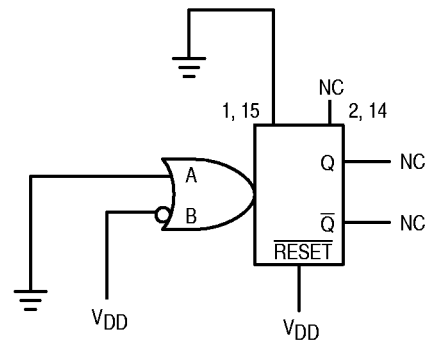

**Figure 10. Connection of Unused Sections**

## OUTLINE DIMENSIONS

### L SUFFIX CERAMIC DIP PACKAGE CASE 620-10 ISSUE V

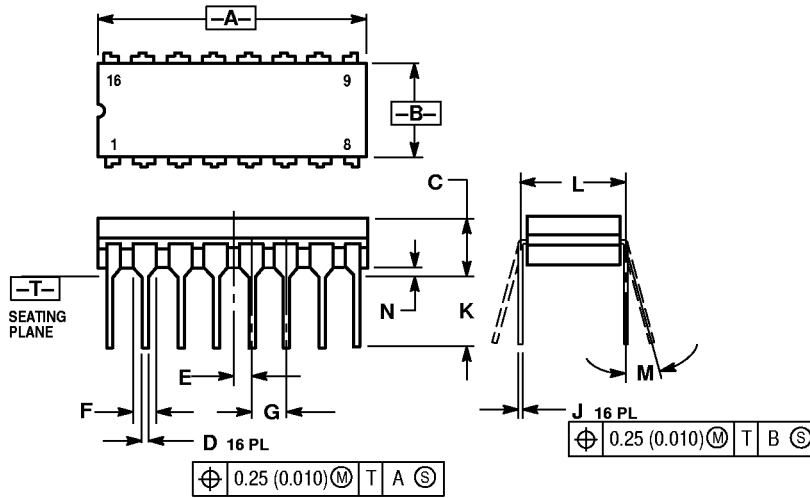

**NOTES:**

1. DIMENSIONING AND TOLERANCING PER ANSI Y14.5M, 1982.
2. CONTROLLING DIMENSION: INCH.
3. DIMENSION L TO CENTER OF LEAD WHEN FORMED PARALLEL.
4. DIMENSION F MAY NARROW TO 0.76 (0.030) WHERE THE LEAD ENTERS THE CERAMIC BODY.

DIM	INCHES		MILLIMETERS	
	MIN	MAX	MIN	MAX
A	0.750	0.785	19.05	19.93
B	0.240	0.295	6.10	7.49
C	—	0.200	—	5.08
D	0.015	0.020	0.39	0.50
E	0.050 BSC		1.27 BSC	
F	0.055	0.065	1.40	1.65
G	0.100 BSC		2.54 BSC	
H	0.008	0.015	0.21	0.38
K	0.125	0.170	3.18	4.31
L	0.300 BSC		7.62 BSC	
M	0° 15°		0° 15°	
N	0.020	0.040	0.51	1.01

### P SUFFIX PLASTIC DIP PACKAGE CASE 648-08 ISSUE R

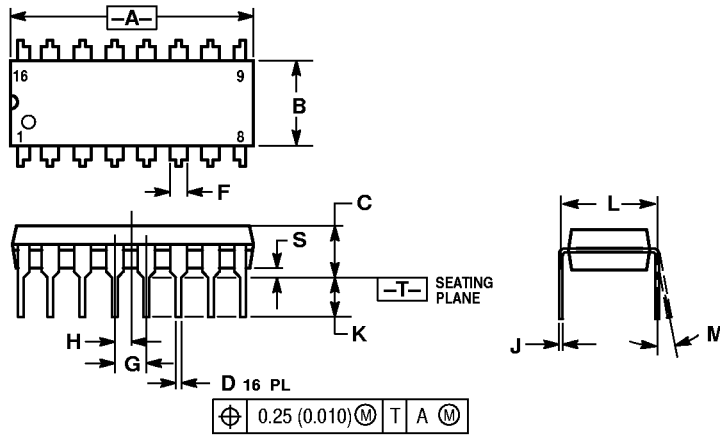

**NOTES:**

1. DIMENSIONING AND TOLERANCING PER ANSI Y14.5M, 1982.
2. CONTROLLING DIMENSION: INCH.
3. DIMENSION L TO CENTER OF LEADS WHEN FORMED PARALLEL.
4. DIMENSION B DOES NOT INCLUDE MOLD FLASH.
5. ROUNDED CORNERS OPTIONAL.

DIM	INCHES		MILLIMETERS	
	MIN	MAX	MIN	MAX
A	0.740	0.770	18.80	19.55
B	0.250	0.270	6.35	6.85
C	0.145	0.175	3.69	4.44
D	0.015	0.021	0.39	0.53
F	0.040	0.70	1.02	1.77
G	0.100 BSC		2.54 BSC	
H	0.050 BSC		1.27 BSC	
J	0.008	0.015	0.21	0.38
K	0.110	0.130	2.80	3.30
L	0.295	0.305	7.50	7.74
M	0° 10°		0° 10°	
S	0.020	0.040	0.51	1.01

## OUTLINE DIMENSIONS

### D SUFFIX PLASTIC SOIC PACKAGE CASE 751B-05 ISSUE J

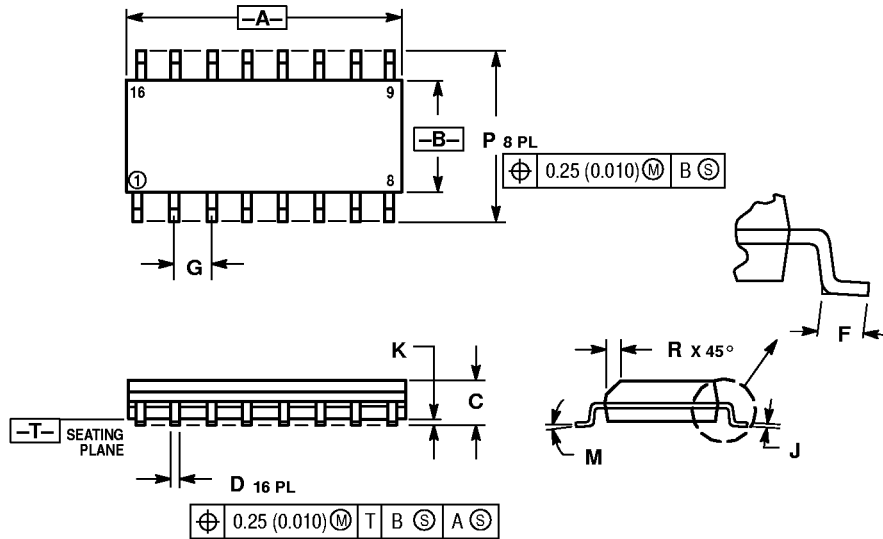

**NOTES:**

1. DIMENSIONING AND TOLERANCING PER ANSI Y14.5M, 1982.
2. CONTROLLING DIMENSION: MILLIMETER.
3. DIMENSIONS A AND B DO NOT INCLUDE MOLD PROTRUSION.
4. MAXIMUM MOLD PROTRUSION 0.15 (0.006) PER SIDE.
5. DIMENSION D DOES NOT INCLUDE DAMBAR PROTRUSION. ALLOWABLE DAMBAR PROTRUSION SHALL BE 0.127 (0.005) TOTAL IN EXCESS OF THE D DIMENSION AT MAXIMUM MATERIAL CONDITION.

DIM	MILLIMETERS		INCHES	
	MIN	MAX	MIN	MAX
A	9.80	10.00	0.386	0.393
B	3.80	4.00	0.150	0.157
C	1.35	1.75	0.054	0.068
D	0.35	0.49	0.014	0.019
F	0.40	1.25	0.016	0.049
G	1.27 BSC		0.050 BSC	
J	0.19	0.25	0.008	0.009
K	0.10	0.25	0.004	0.009
M	0°	7°	0°	7°
P	5.80	6.20	0.229	0.244
R	0.25	0.50	0.010	0.019

Motorola reserves the right to make changes without further notice to any products herein. Motorola makes no warranty, representation or guarantee regarding the suitability of its products for any particular purpose, nor does Motorola assume any liability arising out of the application or use of any product or circuit, and specifically disclaims any and all liability, including without limitation consequential or incidental damages. "Typical" parameters which may be provided in Motorola data sheets and/or specifications can and do vary in different applications and actual performance may vary over time. All operating parameters, including "Typicals" must be validated for each customer application by customer's technical experts. Motorola does not convey any license under its patent rights nor the rights of others. Motorola products are not designed, intended, or authorized for use as components in systems intended for surgical implant into the body, or other applications intended to support or sustain life, or for any other application in which the failure of the Motorola product could create a situation where personal injury or death may occur. Should Buyer purchase or use Motorola products for any such unintended or unauthorized application, Buyer shall indemnify and hold Motorola and its officers, employees, subsidiaries, affiliates, and distributors harmless against all claims, costs, damages, and expenses, and reasonable attorney fees arising out of, directly or indirectly, any claim of personal injury or death associated with such unintended or unauthorized use, even if such claim alleges that Motorola was negligent regarding the design or manufacture of the part. Motorola and are registered trademarks of Motorola, Inc. Motorola, Inc. is an Equal Opportunity/Affirmative Action Employer.

**How to reach us:**

**USA/EUROPE/Locations Not Listed:** Motorola Literature Distribution;  
P.O. Box 20912; Phoenix, Arizona 85036. 1-800-441-2447 or 602-303-5454

**JAPAN:** Nippon Motorola Ltd.; Tatsumi-SPD-JLDC, 6F Seibu-Butsuryu-Center,  
3-14-2 Tatsumi Koto-Ku, Tokyo 135, Japan. 03-81-3521-8315

**MFAX:** RMFAX0@email.sps.mot.com – TOUCHTONE 602-244-6609  
**INTERNET:** <http://Design-NET.com>

**ASIA/PACIFIC:** Motorola Semiconductors H.K. Ltd.; 8B Tai Ping Industrial Park,  
51 Ting Kok Road, Tai Po, N.T., Hong Kong. 852-26629298



MC14528B/D

