

# SN54157, SN54LS157, SN54LS158, SN54S157, SN54S158, SN74157, SN74LS157, SN74LS158, SN74S157, SN74S158 QUADRUPLE 2-LINE TO 1-LINE DATA SELECTORS/MULTIPLEXERS

MARCH 1974 - REVISED MARCH 1988

- Buffered Inputs and Outputs
- Three Speed/Power Ranges Available

TYPES	TYPICAL AVERAGE PROPAGATION TIME	TYPICAL POWER DISSIPATION
'157	9 ns	150 mW
'LS157	9 ns	49 mW
'S157	5 ns	250 mW
'LS158	7 ns	24 mW
'S158	4 ns	195 mW

### applications

- Expand Any Data Input Point
- Multiplex Dual Data Buses
- Generate Four Functions of Two Variables (One Variable Is Common)
- Source Programmable Counters

### description

These monolithic data selectors/multiplexers contain inverters and drivers to supply full on-chip data selection to the four output gates. A separate strobe input is provided. A 4-bit word is selected from one of two sources and is routed to the four outputs. The '157, 'LS157, and 'S157 present true data whereas the 'LS158 and 'S158 present inverted data to minimize propagation delay time.

FUNCTION TABLE

STROBE G	INPUTS		OUTPUT Y		
	SELECT A/B	A	B	'157, 'LS157,'S157	'LS158 'S158
H	X	X	X	L	H
L	L	L	X	L	H
L	L	H	X	H	L
L	H	X	L	L	H
L	H	X	H	H	L

H = high level, L = low level, X = irrelevant

### absolute maximum ratings over operating free-air temperature range (unless otherwise noted)

Supply voltage, V <sub>CC</sub> (See Note 1)	7 V
Input voltage: '157, 'S158	5.5 V
'LS157, 'LS158	7 V
Operating free-air temperature range: SN54'	-55°C to 125°C
SN74'	0°C to 70°C
Storage temperature range	-65°C to 150°C

NOTE 1: Voltage values are with respect to network ground terminal.

SN54157, SN54LS157, SN54S157,  
SN54LS158, SN54S158 . . . J OR W PACKAGE  
SN74157 . . . N PACKAGE  
SN74LS157, SN74S157,  
SN74LS158, SN74S158 . . . D OR N PACKAGE  
(TOP VIEW)

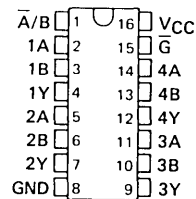

SN54LS157, SN54S157, SN54LS158,  
SN54S158 . . . FK PACKAGE  
(TOP VIEW)

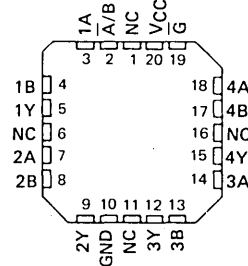

NC - No internal connection

2

TTL Devices

PRODUCTION DATA documents contain information current as of publication date. Products conform to specifications per the terms of Texas Instruments standard warranty. Production processing does not necessarily include testing of all parameters.

TEXAS  
INSTRUMENTS

POST OFFICE BOX 655012 • DALLAS, TEXAS 75265

2-483

**SN54157, SN54LS157, SN54LS158, SN54S157, SN54S158,  
SN74157, SN74LS157, SN74LS158, SN74S157, SN74S158  
QUADRUPLE 2-LINE TO 1-LINE DATA SELECTORS/MULTIPLEXERS**

logic symbols†

logic diagram (positive logic)

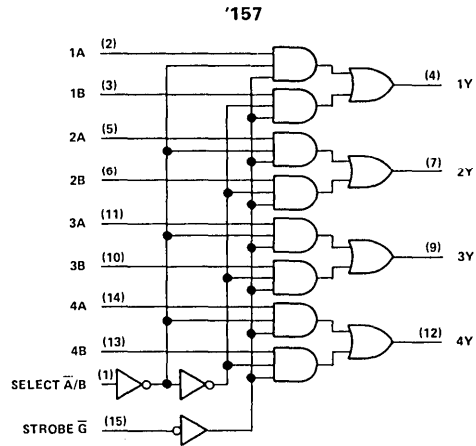
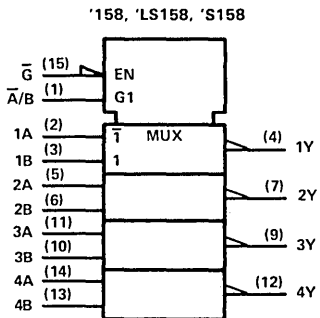
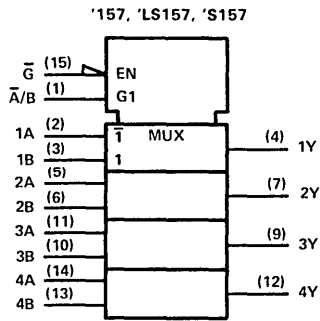

2

TTL Devices

†These symbols are in accordance with ANSI/IEEE Std. 91-1984 and IEC Publication 617-12.

Pin numbers shown are for D, J, N, and W packages.

schematics of inputs and outputs

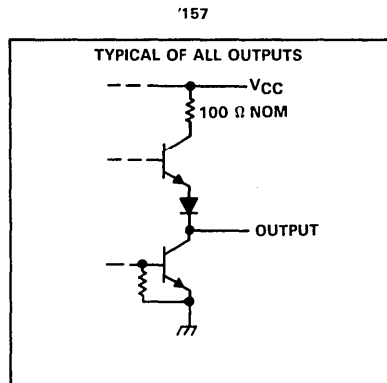
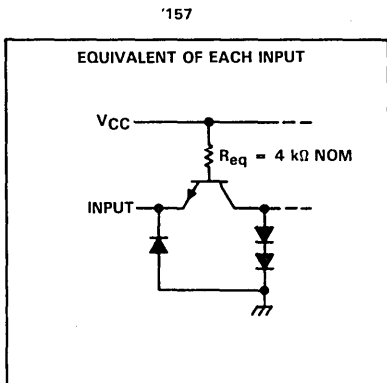

**SN54LS157, SN54LS158, SN54S157, SN54S158,  
SN74LS157, SN74LS158, SN74S157, SN74S158  
QUADRUPLE 2-LINE TO 1-LINE DATA SELECTORS/MULTIPLEXERS**

logic diagrams (positive logic)

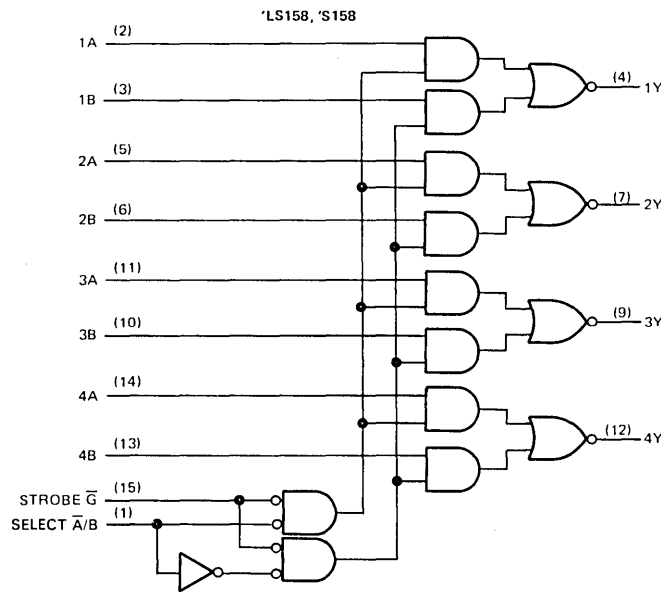
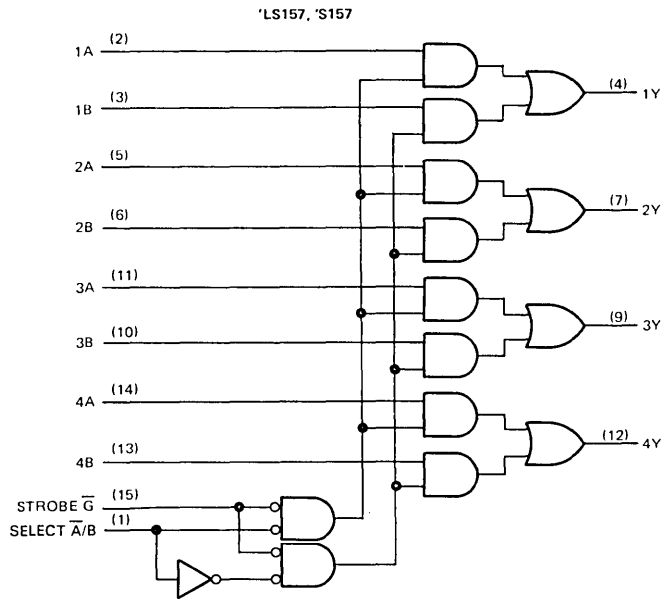

Pin numbers shown are for D, J, N, and W packages.

schematics of inputs and outputs

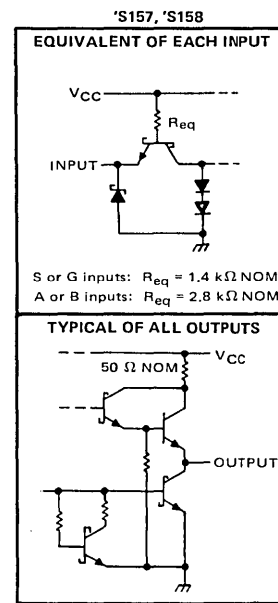
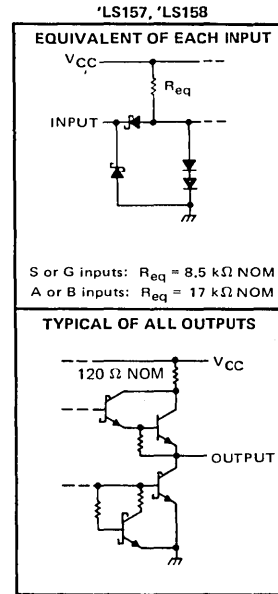

**2**  
TTL Devices

**SN54157, SN74157**  
**QUADRUPLE 2-LINE TO 1-LINE DATA SELECTORS/MULTIPLEXERS**

recommended operating conditions

	SN54157			SN74157			UNIT
	MIN	NOM	MAX	MIN	NOM	MAX	
Supply voltage, $V_{CC}$	4.5	5	5.5	4.75	5	5.25	V
High-level output current, $I_{OH}$			-800			-800	$\mu$ A
Low-level output current, $I_{OL}$			16			16	mA
Operating free-air temperature, $T_A$	-55		125	0		70	$^{\circ}$ C

electrical characteristics over recommended operating free-air temperature range (unless otherwise noted)

PARAMETER	TEST CONDITIONS†	SN54157			SN74157			UNIT
		MIN	TYP‡	MAX	MIN	TYP‡	MAX	
$V_{IH}$ High-level input voltage		2			2			V
$V_{IL}$ Low-level input voltage				0.8			0.8	V
$V_{IK}$ Input clamp voltage	$V_{CC} = \text{MIN}, I_I = -12 \text{ mA}$			-1.5			-1.5	V
$V_{OH}$ High-level output voltage	$V_{CC} = \text{MIN}, V_{IH} = 2 \text{ V}, V_{IL} = 0.8 \text{ V}, I_{OH} = -800 \mu\text{A}$	2.4	3.4		2.4	3.4		V
$V_{OL}$ Low-level output voltage	$V_{CC} = \text{MIN}, V_{IH} = 2 \text{ V}, V_{IL} = 0.8 \text{ V}, I_{OL} = 16 \text{ mA}$		0.2	0.4		0.2	0.4	V
$I_I$ Input current at maximum input voltage	$V_{CC} = \text{MAX}, V_I = 5.5 \text{ V}$			1			1	mA
$I_{IH}$ High-level input current	$V_{CC} = \text{MAX}, V_I = 2.4 \text{ V}$			40			40	$\mu$ A
$I_{IL}$ Low-level input current	$V_{CC} = \text{MAX}, V_I = 0.4 \text{ V}$			-1.6			-1.6	mA
$I_{OS}$ Short-circuit output current §	$V_{CC} = \text{MAX}$	-20		-55	-18		-55	mA
$I_{CC}$ Supply current	$V_{CC} = \text{MAX}, \text{ See Note 2}$		30	48		30	48	mA

† For conditions shown as MIN or MAX, use the appropriate value specified under recommended operating conditions.

‡ All typical values are at  $V_{CC} = 5 \text{ V}, T_A = 25^{\circ}\text{C}$ .

§ Not more than one output should be shorted at a time and duration of short-circuit should not exceed one second.

NOTE 2:  $I_{CC}$  is measured with 4.5 V applied to all inputs and all outputs open.

switching characteristics,  $V_{CC} = 5 \text{ V}, T_A = 25^{\circ}\text{C}$

PARAMETER¶	FROM (INPUT)	TEST CONDITIONS	MIN	TYP	MAX	UNIT
$t_{PLH}$	Data	$C_L = 15 \text{ pF}, R_L = 400 \Omega, \text{ See Note 3}$		9	14	ns
$t_{PHL}$				9	14	
$t_{PLH}$	Strobe $\bar{G}$			13	20	ns
$t_{PHL}$				14	21	
$t_{PLH}$	Select $\bar{A}/\bar{B}$			15	23	ns
$t_{PHL}$				18	27	

¶  $t_{PLH}$  = propagation delay time, low-to-high-level output

$t_{PHL}$  = propagation delay time, high-to-low-level output

NOTE 3: Load circuits and voltage waveforms are shown in Section 1.

2  
TTL Devices

## SN54LS157, SN54LS158, SN74LS157, SN74LS158 QUADRUPLE 2-LINE TO 1-LINE DATA SELECTORS/MULTIPLEXERS

### recommended operating conditions

		SN54LS'			SN74LS'			UNIT	
		MIN	NOM	MAX	MIN	NOM	MAX		
V <sub>CC</sub>	Supply voltage	4.5	5	5.5	4.75	5	5.25	V	
I <sub>OH</sub>	High-level output current				-400			μA	
I <sub>OL</sub>	Low-level output current				4			8	
T <sub>A</sub>	Operating free-air temperature	-55			125			0	70
								°C	

### electrical characteristics over recommended operating free-air temperature range (unless otherwise noted)

PARAMETER	TEST CONDITIONS†	SN54LS'			SN74LS'			UNIT	
		MIN	TYP‡	MAX	MIN	TYP‡	MAX		
V <sub>IH</sub>	High-level input voltage	2			2			V	
V <sub>IL</sub>	Low-level input voltage				0.7			0.8	
V <sub>IK</sub>	Input clamp voltage	V <sub>CC</sub> = MIN, I <sub>I</sub> = -18 mA			-1.5			-1.5	
V <sub>OH</sub>	High-level output voltage	V <sub>CC</sub> = MIN, V <sub>IH</sub> = 2 V, V <sub>IL</sub> = MAX, I <sub>OH</sub> = -400 μA			2.5 3.4			2.7 3.4	
V <sub>OL</sub>	Low-level output voltage	V <sub>CC</sub> = MIN, V <sub>IH</sub> = 2 V, V <sub>IL</sub> = MAX			I <sub>OL</sub> = 4 mA I <sub>OL</sub> = 8 mA			0.25 0.4 0.25 0.4	
I <sub>I</sub>	Input current at maximum input voltage	A/B or G		V <sub>CC</sub> = MAX, V <sub>I</sub> = 7 V			0.2		mA
		A or B					0.1		
I <sub>IH</sub>	High-level input current	A/B or G		V <sub>CC</sub> = MAX, V <sub>I</sub> = 2.7 V			40		μA
		A or B					20		
I <sub>IL</sub>	Low-level input current	A/B or G		V <sub>CC</sub> = MAX, V <sub>I</sub> = 0.4 V			-0.8		mA
		A or B					-0.4		
I <sub>OS</sub>	Short-circuit output current§	V <sub>CC</sub> = MAX			-20 -100			-20 -100	mA
I <sub>CC</sub>	Supply current	V <sub>CC</sub> = MAX, See Note 2		'LS157	9.7	16	9.7	16	mA
				'LS158	4.8	8	4.8	8	
		V <sub>CC</sub> = MAX, All A inputs at 4.5 V, All other inputs at 0 V		'LS158	6.5	11	6.5	11	

† For conditions shown as MIN or MAX, use the appropriate value specified under recommended operating conditions.

‡ All typical values are at V<sub>CC</sub> = 5 V, T<sub>A</sub> = 25°C.

§ Not more than one output should be shorted at a time and duration of short-circuit should not exceed one second.

NOTE 2: I<sub>CC</sub> is measured with 4.5 V applied to all inputs and all outputs open.

### switching characteristics, V<sub>CC</sub> = 5 V, T<sub>A</sub> = 25°C

PARAMETER¶	FROM (INPUT)	TEST CONDITIONS	'LS157			'LS158			UNIT
			MIN	TYP	MAX	MIN	TYP	MAX	
t <sub>PLH</sub>	Data	C <sub>L</sub> = 15 pF, R <sub>L</sub> = 2 kΩ, See Note 3	9	14		7	12	ns	
t <sub>PHL</sub>			9	14		10	15		
t <sub>PLH</sub>	Strobe G		13	20		11	17	ns	
t <sub>PHL</sub>			14	21		18	24		
t <sub>PLH</sub>	Select A/B		15	23		13	20	ns	
t <sub>PHL</sub>			18	27		16	24		

¶ t<sub>PLH</sub> = propagation delay time, low-to-high-level output

t<sub>PHL</sub> = propagation delay time, high-to-low-level output

NOTE 3: Load circuits and voltage diagrams are shown in Section 1.

2

TTL Devices

**TEXAS  
INSTRUMENTS**

POST OFFICE BOX 655012 • DALLAS, TEXAS 75265

2-487

**SN54S157, SN54S158, SN74S157, SN74S158**  
**QUADRUPLE 2-LINE TO 1-LINE DATA SELECTORS/MULTIPLEXERS**

recommended operating conditions

	SN54S157 SN54S158			SN74S157 SN74S158			UNIT
	MIN	NOM	MAX	MIN	NOM	MAX	
Supply voltage, $V_{CC}$	4.5	5	5.5	4.75	5	5.25	V
High-level output current, $I_{OH}$			-1			-1	mA
Low-level output current, $I_{OL}$			20			20	mA
Operating free-air temperature, $T_A$	-55		125	0		70	$^{\circ}$ C

electrical characteristics over recommended operating free-air temperature range (unless otherwise noted)

PARAMETER	TEST CONDITIONS <sup>†</sup>	SN54S157 SN74S157		SN54S158 SN74S158		UNIT
		MIN	TYP <sup>‡</sup>	MAX	MIN	
$V_{IH}$ High-level input voltage		2		2		V
$V_{IL}$ Low-level input voltage				0.8		V
$V_{IK}$ Input clamp voltage	$V_{CC} = \text{MIN}, I_I = -18 \text{ mA}$			-1.2		V
$V_{OH}$ High-level output voltage	$V_{CC} = \text{MIN}, V_{IH} = 2 \text{ V},$ $V_{IL} = 0.8 \text{ V}, I_{OH} = -1 \text{ mA}$	Series 54S 2.5	3.4	Series 74S 2.7	3.4	V
$V_{OL}$ Low-level output voltage	$V_{CC} = \text{MIN}, V_{IH} = 2 \text{ V},$ $V_{IL} = 0.8 \text{ V}, I_{OL} = 20 \text{ mA}$	0.5		0.5		V
$I_I$ Input current at maximum input voltage	$V_{CC} = \text{MAX}, V_I = 5.5 \text{ V}$	1		1		mA
$I_{IH}$ High-level input current	$\bar{A}/\bar{B}$ or $\bar{G}$	100		100		$\mu$ A
	A or B	50		50		
$I_{IL}$ Low-level input current	$\bar{A}/\bar{B}$ or $\bar{G}$	-4		-4		mA
	A or B	-2		-2		
$I_{OS}$ Short-circuit output current <sup>§</sup>	$V_{CC} = \text{MAX}$	-40	-100	-40	-100	mA
$I_{CC}$ Supply current	$V_{CC} = \text{MAX},$ All inputs at 4.5 V, See Note 2	50 78		39 61		mA
	$V_{CC} = \text{MAX},$ A inputs at 4.5 V, B,G,S, inputs at 0 V, See Note 2			81		

<sup>†</sup> For conditions shown as MIN or MAX, use the appropriate value specified under recommended operating conditions.

<sup>‡</sup> All typical values are at  $V_{CC} = 5 \text{ V}, T_A = 25^{\circ}\text{C}$ .

<sup>§</sup> Not more than one output should be shorted at a time, and duration of the short circuit should not exceed one second.

Note 2:  $I_{CC}$  is measured with all outputs open.

switching characteristics,  $V_{CC} = 5 \text{ V}, T_A = 25^{\circ}\text{C}$

PARAMETER <sup>¶</sup>	FROM (INPUT)	TEST CONDITIONS	SN54S157 SN74S157		SN54S158 SN74S158		UNIT
			MIN	TYP	MAX	MIN	
$t_{PLH}$	Data	$C_L = 15 \text{ pF},$ $R_L = 280 \Omega,$ See Note 3	5	7.5	4	6	ns
$t_{PHL}$			4.5	6.5	4	6	
$t_{PLH}$	Strobe $\bar{G}$		8.5	12.5	6.5	11.5	ns
$t_{PHL}$			7.5	12	7	12	
$t_{PLH}$	Select $\bar{A}/\bar{B}$		9.5	15	8	12	ns
$t_{PHL}$			9.5	15	8	12	

<sup>¶</sup> $t_{PLH}$  = propagation delay time, low-to-high-level output

<sup>¶</sup> $t_{PHL}$  = propagation delay time, high-to-low-level output

NOTE 3: Load circuits and voltage waveforms are shown in Section 1.

2  
TTL Devices