

SN5453, SN7453 EXPANDABLE 4-WIDE AND-OR-INVERT GATES

DECEMBER 1983—REVISED MARCH 1988

- Package Options Include Plastic and Ceramic DIPs and Ceramic Flat Packages
- Dependable Texas Instruments Quality and Reliability

description

These devices are expandable 4-wide AND-OR-INVERT gates. They perform the Boolean function $Y = AB + CD + EF + GH + \bar{X}$ with X = output of SN5460/SN7460.

The SN5453 is characterized for operation over the full military temperature range of -55°C to 125°C . The SN7453 is characterized for operation from 0°C to 70°C .

logic symbol†

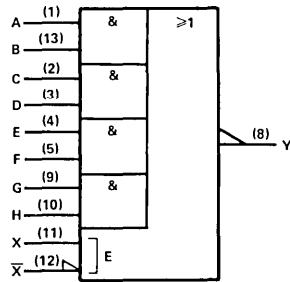

positive logic: $Y = AB + CD + EF + GH + \bar{X}$
X = output of SN5460/SN7460

†This symbol is in accordance with ANSI/IEEE Std 91-1984 and IEC Publication 617-12.
Pin numbers shown are for J and N packages.

logic diagram (positive logic)

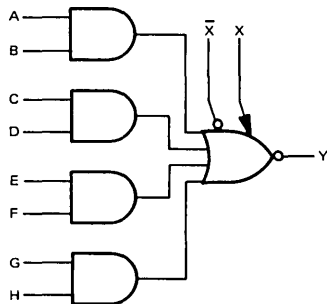

SN5453 . . . J PACKAGE
SN7453 . . . N PACKAGE
(TOP VIEW)

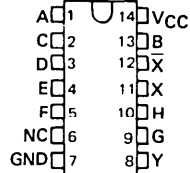

SN5453 . . . W PACKAGE
(TOP VIEW)

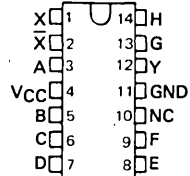

schematic

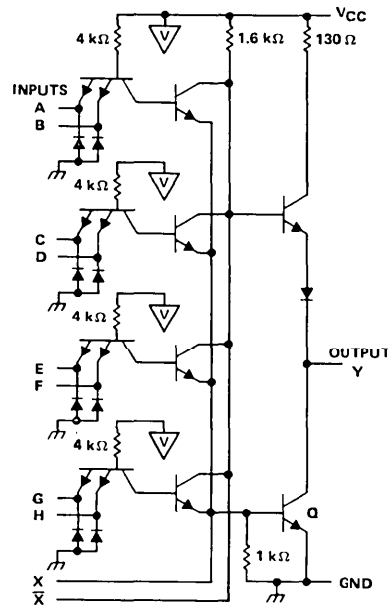

Resistor values shown are nominal.
If expander is not used, leave X and X-bar open.

PRODUCTION DATA documents contain information current as of publication date. Products conform to specifications per the terms of Texas Instruments standard warranty. Production processing does not necessarily include testing of all parameters.

TEXAS
INSTRUMENTS

POST OFFICE BOX 655012 • DALLAS, TEXAS 75265

2-199

2

TTL Devices

SN5453, SN7453
EXPANDABLE 4-WIDE AND-OR INVERT GATES

absolute maximum ratings over operating free-air temperature range (unless otherwise noted)

Supply voltage, V_{CC} (see Note 1)	7 V
Input voltage	5.5 V
Operating free-air temperature range: SN5453	-55°C to 125°C
SN7453	0°C to 70°C
Storage temperature range	-65°C to 150°C

NOTE 1: Voltage values are with respect to network ground terminals.

recommended operating conditions

	SN5453			SN7453			UNIT
	MIN	NOM	MAX	MIN	NOM	MAX	
V_{CC} Supply voltage	4.5	5	5.5	4.75	5	5.25	V
V_{IH} High-level input voltage	2			2			V
V_{IL} Low-level input voltage			0.8			0.8	V
I_{OH} High-level output current			-0.4			-0.4	mA
I_{OL} Low-level output current			16			16	mA
T_A Operating free-air temperature	-55		125	0		70	°C

2

TTL Devices

electrical characteristics over recommended operating free-air temperature range (unless otherwise noted)

PARAMETER	TEST CONDITIONS†	SN5453		SN7453		UNIT		
		MIN	TYP‡	MAX	MIN		TYP‡	MAX
V_{IK}	$V_{CC} = \text{MIN}, I_I = -12 \text{ mA}$			-1.5		-1.5	V	
V_{OH}	$V_{CC} = \text{MIN}, V_{IL} = 0.8 \text{ V}, I_{OH} = -0.4 \text{ mA}$	2.4	3.4	2.4	3.4		V	
V_{OL}	$V_{CC} = \text{MIN}, V_{IH} = 2 \text{ V}, I_{OL} = 16 \text{ mA}$	0.2	0.4	0.2	0.4		V	
I_I	$V_{CC} = \text{MAX}, V_I = 5.5 \text{ V}$			1		1	mA	
I_{IH}	$V_{CC} = \text{MAX}, V_{IH} = 2.4 \text{ V}$			40		40	µA	
I_{IL}	$V_{CC} = \text{MAX}, V_{IL} = 0.4 \text{ V}$			-1.6		-1.6	mA	
$I_{OS}§$	$V_{CC} = \text{MAX}$	-20		-55	-18	-55	mA	
I_{CCH}	$V_{CC} = \text{MAX}, V_I = 0 \text{ V}$			4	8	8	mA	
I_{CCL}	$V_{CC} = \text{MAX}, \text{ See Note 2}$			5.1	9.5	5.1	9.5	mA
$I_{\bar{X}}¶$	$V_{\bar{X}\bar{X}} = 0.4 \text{ V}, I_{OL} = 16 \text{ mA}$			-2.9		-3.1	mA	
$V_{BE(Q)}¶$	$I_X + I_{\bar{X}} = 0.41 \text{ mA}, R_{\bar{X}\bar{X}} = 0, I_{OL} = 16 \text{ mA}$			1.1			V	
	$I_X + I_{\bar{X}} = 0.62 \text{ mA}, R_{\bar{X}\bar{X}} = 0, I_{OL} = 16 \text{ mA}$					1	V	
$V_{OH}¶$	$I_X = 0.15 \text{ mA}, I_{\bar{X}} = -0.15 \text{ mA}, I_{OH} = -0.4 \text{ mA}$	2.4	3.4				V	
	$I_X = 0.27 \text{ mA}, I_{\bar{X}} = -0.27 \text{ mA}, I_{OH} = -0.4 \text{ mA}$			2.4	3.4		V	
$V_{OL}¶$	$I_X + I_{\bar{X}} = 0.3 \text{ mA}, R_{\bar{X}\bar{X}} = 138 \Omega, I_{OL} = 16 \text{ mA}$	0.2	0.4				V	
	$I_X + I_{\bar{X}} = 0.43 \text{ mA}, R_{\bar{X}\bar{X}} = 130 \Omega, I_{OL} = 16 \text{ mA}$					0.2	0.4	

† For conditions shown as MIN or MAX, use the appropriate value specified under recommended operating conditions.

‡ All typical values are at $V_{CC} = 5 \text{ V}, T_A = 25^\circ\text{C}$.

§ Not more than one output should be shorted at a time.

¶ Using expander inputs, $V_{CC} = \text{MIN}, T_A = \text{MIN}$, except typical values.

NOTE 2: All inputs of one AND gate at 4.5 V, all others at GND.

switching characteristics, $V_{CC} = 5 \text{ V}, T_A = 25^\circ\text{C}$ (see note 3)

PARAMETER	FROM (INPUT)	TO (OUTPUT)	TEST CONDITIONS	MIN	TYP	MAX	UNIT
t_{PLH}	Any	Y	$R_L = 400 \Omega, C_L = 15 \text{ pF} \#$		13	22	ns
t_{PHL}					8	15	ns

Expander pins open.

NOTE 3: Load circuits and voltage waveforms are shown in Section 1.