

## DUAL 4-INPUT NAND GATE

- **HIGH SPEED**  
 $t_{PD} = 10 \text{ ns (TYP.) at } V_{CC} = 5\text{V}$
- **LOW POWER DISSIPATION**  
 $I_{CC} = 1 \mu\text{A (MAX.) at } T_A = 25^\circ\text{C}$
- **HIGH NOISE IMMUNITY**  
 $V_{NIH} = V_{NIL} = 28\% V_{CC} \text{ (MIN.)}$
- **OUTPUT DRIVE CAPABILITY**  
 10 LSTTL LOADS
- **SYMMETRICAL OUTPUT IMPEDANCE**  
 $|I_{OH}| = I_{OL} = 4 \text{ mA (MIN.)}$
- **BALANCED PROPAGATION DELAYS**  
 $t_{PLH} = t_{PHL}$
- **WIDE OPERATING VOLTAGE RANGE**  
 $V_{CC} \text{ (OPR)} = 2\text{V to } 6\text{V}$
- **PIN AND FUNCTION COMPATIBLE**  
 WITH 54/74LS20

### DESCRIPTION

The M54/74HC20 is a high speed CMOS DUAL 4-INPUT NAND GATE fabricated in silicon gate C<sup>2</sup>MOS technology. It has the same high speed performance of LSTTL combined with true CMOS low power consumption.

The internal circuit is composed of 3 stages including buffered output, which gives high noise immunity and a stable output. All inputs are equipped with protection circuits against static discharge and transient excess voltage.

### INPUT AND OUTPUT EQUIVALENT CIRCUIT

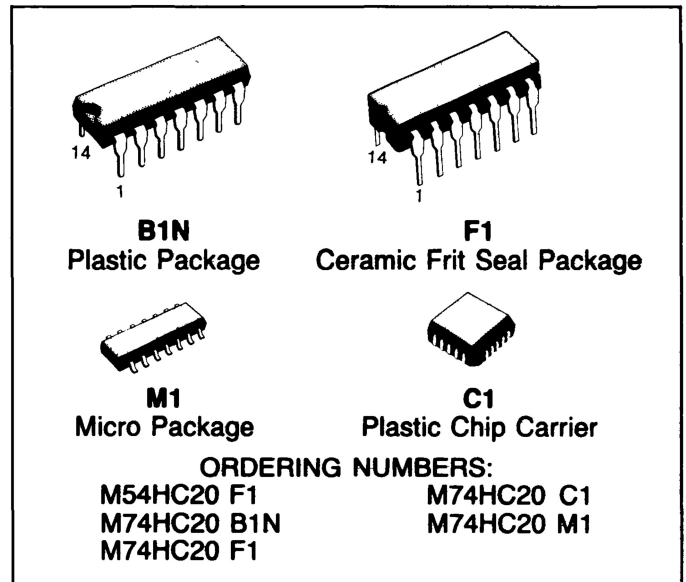
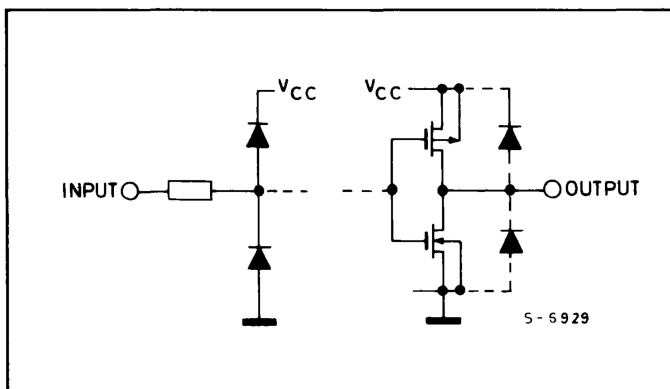

### PIN CONNECTIONS (top view)

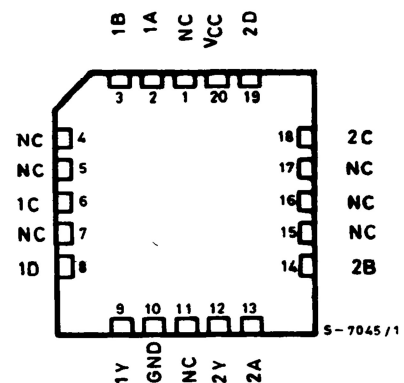
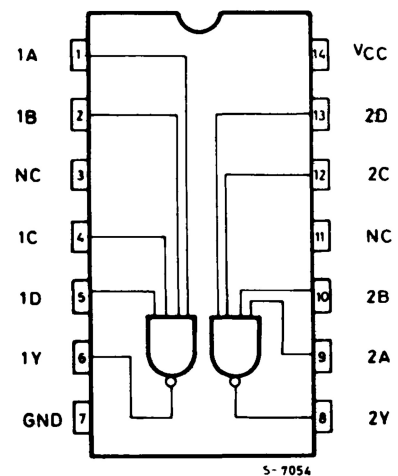

NC =  
No Internal  
Connection

**LOGIC DIAGRAM (per Gate)**

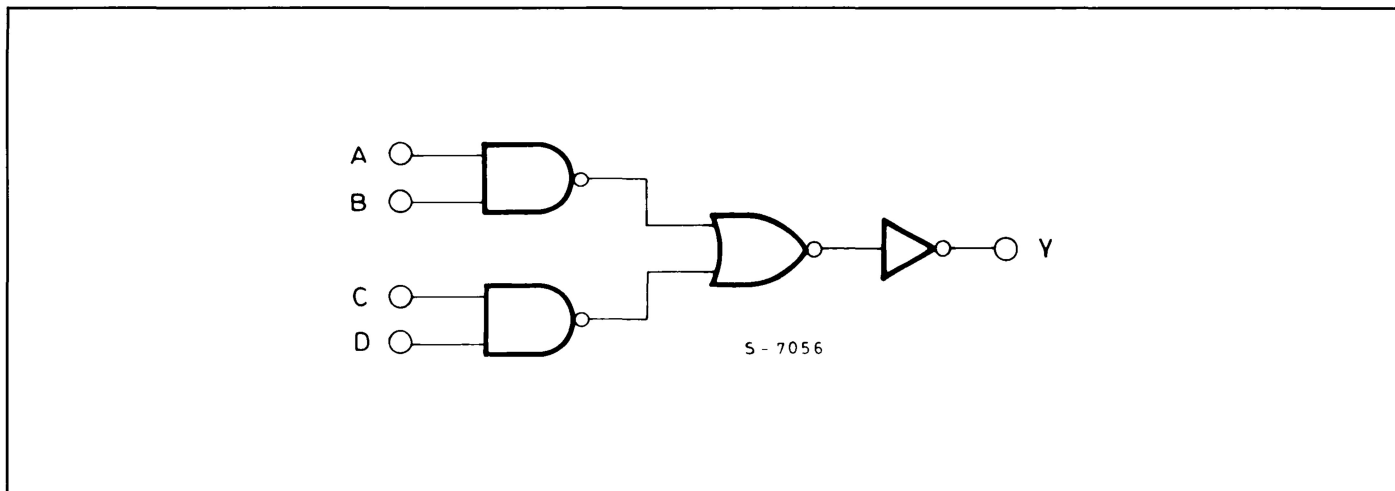

**ABSOLUTE MAXIMUM RATINGS**

Symbol	Parameter	Value	Unit
$V_{CC}$	Supply Voltage	- 0.5 to 7	V
$V_I$	DC Input Voltage	- 0.5 to $V_{CC} + 0.5$	V
$V_O$	DC Output Voltage	- 0.5 to $V_{CC} + 0.5$	V
$I_{IK}$	DC Input Diode Current	$\pm 20$	mA
$I_{OK}$	DC Output Diode Current	$\pm 20$	mA
$I_O$	DC Output Source Sink Current Per Output Pin	$\pm 25$	mA
$I_{CC}$ or $I_{GND}$	DC $V_{CC}$ or Ground Current	$\pm 50$	mA
$P_D$	Power Dissipation	500 (*)	mW
$T_{stg}$	Storage Temperature	- 65 to 150	$^{\circ}C$

Absolute Maximum Ratings are those values beyond which damage to the device may occur. Functional operation under these condition is not implied.

(\*) 500 mW:  $\cong 65^{\circ}C$  derate to 300 mW by 10 mW/ $^{\circ}C$ :  $65^{\circ}C$  to  $85^{\circ}C$

**RECOMMENDED OPERATING CONDITIONS**

Symbol	Parameter	Value	Unit	
$V_{CC}$	Supply Voltage	2 to 6	V	
$V_I$	Input Voltage	0 to $V_{CC}$	V	
$V_O$	Output Voltage	0 to $V_{CC}$	V	
$T_A$	Operating Temperature	74HC Series 54HC Series	- 40 to 85 - 55 to 125	$^{\circ}C$
$t_r, t_f$	Input Rise and Fall Time	$V_{CC} \begin{cases} 2 \text{ V} \\ 4.5 \text{ V} \\ 6 \text{ V} \end{cases}$	$\begin{cases} 0 \text{ to } 1000 \\ 0 \text{ to } 500 \\ 0 \text{ to } 400 \end{cases}$	ns

## DC SPECIFICATIONS

Symbol	Parameter	V <sub>CC</sub>	Test Condition	T <sub>A</sub> = 25°C 54HC and 74HC			- 40 to 85°C 74HC		- 55 to 125°C 54HC		Unit	
				Min.	Typ.	Max.	Min.	Max.	Min.	Max.		
V <sub>IH</sub>	High Level Input Voltage	2.0		1.5	—	—	1.5	—	1.5	—	V	
		4.5		3.15	—	—	3.15	—	3.15	—		
		6.0		4.2	—	—	4.2	—	4.2	—		
V <sub>IL</sub>	Low Level Input Voltage	2.0		—	—	0.5	—	0.5	—	0.5	V	
		4.5		—	—	1.35	—	1.35	—	1.35		
		6.0		—	—	1.8	—	1.8	—	1.8		
V <sub>OH</sub>	High Level Output Voltage	2.0	V <sub>I</sub>	I <sub>O</sub>	1.9	2.0	—	1.9	—	1.9	—	V
		4.5	V <sub>IH</sub> or V <sub>IL</sub>	- 20 μA	4.4	4.5	—	4.4	—	4.4	—	
		6.0			5.9	6.0	—	5.9	—	5.9	—	
		4.5	V <sub>IH</sub> or V <sub>IL</sub>	- 4.0 mA	4.18	4.31	—	4.13	—	4.10	—	
6.0	- 5.2 mA	5.68		5.8	—	5.63	—	5.60	—			
V <sub>OL</sub>	Low Level Output Voltage	2.0	V <sub>IH</sub> or V <sub>IL</sub>	20 μA	—	0	0.1	—	0.1	—	0.1	V
		4.5			—	0	0.1	—	0.1	—	0.1	
		6.0			—	0	0.1	—	0.1	—	0.1	
		4.5			V <sub>IH</sub> or V <sub>IL</sub>	4.0 mA	—	0.17	0.26	—	0.33	
6.0	5.2 mA	—	0.18	0.26		—	0.33	—	0.40			
I <sub>I</sub>	Input Leakage Current	6.0	V <sub>I</sub> = V <sub>CC</sub> or GND		—	—	±0.1	—	±1	—	±1	μA
I <sub>CC</sub>	Quiescent Supply Current	6.0	V <sub>I</sub> = V <sub>CC</sub> or GND		—	—	1	—	10	—	20	μA

AC ELECTRICAL CHARACTERISTICS (V<sub>CC</sub> = 5V, T<sub>A</sub> = 25°C, C<sub>L</sub> = 15pF, Input t<sub>r</sub> = t<sub>f</sub> = 6ns)

Symbol	Parameter	54HC and 74HC			Unit
		Min.	Typ.	Max.	
t <sub>TLH</sub> t <sub>THL</sub>	Output Transition Time		4	8	ns
t <sub>PLH</sub> t <sub>PHL</sub>	Propagation Delay Time		11	18	ns

AC ELECTRICAL CHARACTERISTICS (C<sub>L</sub> = 50pF, Input t<sub>r</sub> = t<sub>f</sub> = 6ns)

Symbol	Parameter	V <sub>CC</sub>	Test Condition	T <sub>A</sub> = 25°C 54HC and 74HC			- 40 to 85°C 74HC		- 55 to 125°C 54HC		Unit
				Min.	Typ.	Max.	Min.	Max.	Min.	Max.	
t <sub>TLH</sub> t <sub>THL</sub>	Output Transition Time	2.0		—	30	75	—	95	—	110	ns
		4.5		—	8	15	—	19	—	22	
		6.0		—	7	13	—	16	—	19	
t <sub>PLH</sub> t <sub>PHL</sub>	Propagation Delay Time	2.0		—	44	90	—	115	—	135	ns
		4.5		—	11	18	—	23	—	27	
		6.0		—	9	15	—	20	—	23	
C <sub>IN</sub>	Input Capacitance			—	5	10	—	10	—	10	pF
C <sub>PD</sub> (*)	Power Dissipation Capacitance			—	28	—	—	—	—	—	pF

Note (\*) C<sub>PD</sub> is defined as the value of the IC's internal equivalent capacitance which is calculated from the operating current consumption without load. (Refer to Test Circuit)

SWITCHING CHARACTERISTICS TEST CIRCUIT

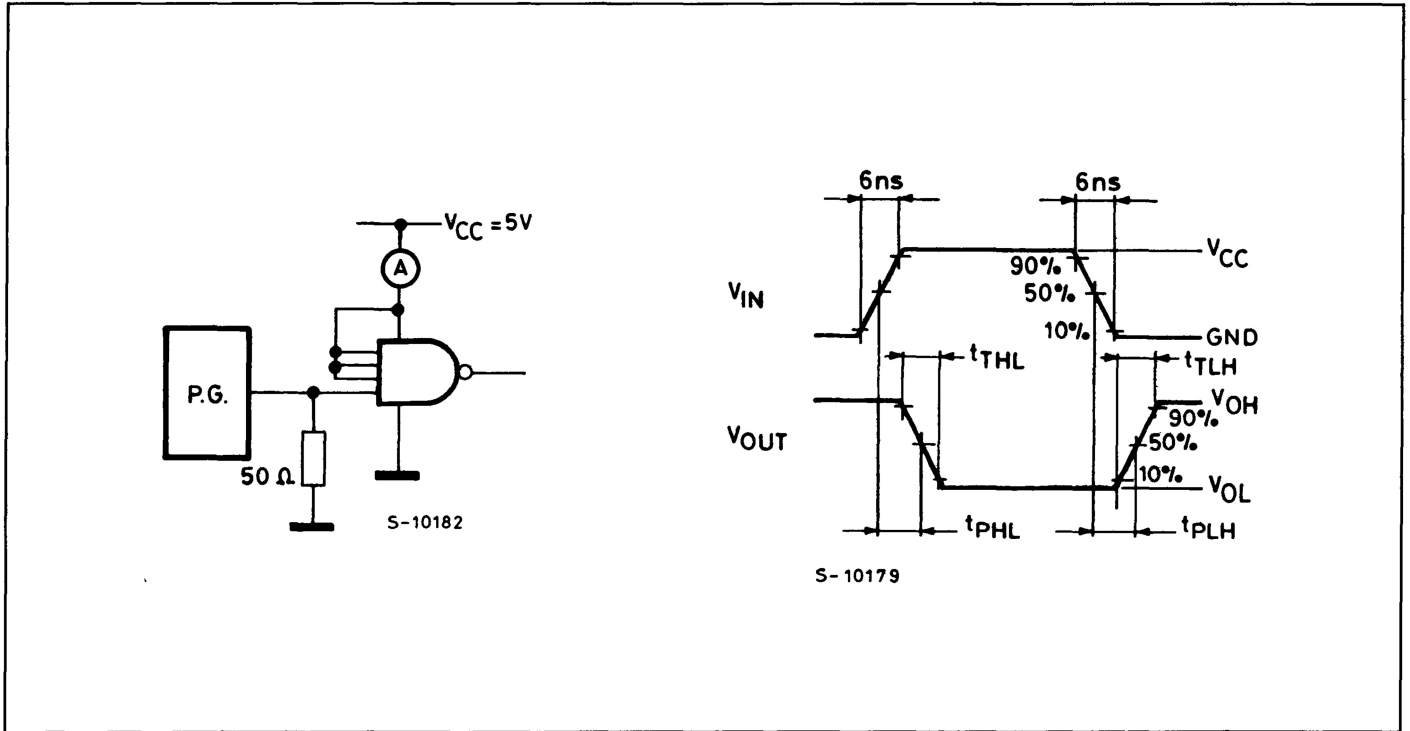

TEST CIRCUIT  $I_{CC}$  (Opr.)

