

DATA SHEET

For a complete data sheet, please also download:

- The IC06 74HC/HCT/HCU/HCMOS Logic Family Specifications
- The IC06 74HC/HCT/HCU/HCMOS Logic Package Information
- The IC06 74HC/HCT/HCU/HCMOS Logic Package Outlines

74HC/HCT30 8-input NAND gate

Product specification
File under Integrated Circuits, IC06

December 1990

8-input NAND gate**74HC/HCT30****FEATURES**

- Output capability: standard
- I_{CC} category: SSI

GENERAL DESCRIPTION

The 74HC/HCT30 are high-speed Si-gate CMOS devices and are pin compatible with low power Schottky TTL (LSTTL). They are specified in compliance with JEDEC standard no. 7A.

The 74HC/HCT30 provide the 8-input NAND function.

QUICK REFERENC DATA

GND = 0 V; $T_{amb} = 25\text{ }^{\circ}\text{C}$; $t_r = t_f = 6\text{ ns}$

SYMBOL	PARAMETER	CONDITIONS	TYPICAL		UNIT
			HC	HCT	
t_{PHL}/t_{PLH}	propagation delay A, B, C, D, E, F, G, H to Y	$C_L = 15\text{ pF}; V_{CC} = 5\text{ V}$	12	12	ns
C_I	input capacitance		3.5	3.5	pF
C_{PD}	power dissipation capacitance per gate	notes 1 and 2	15	15	pF

Notes

1. C_{PD} is used to determine the dynamic power dissipation (P_D in μW):
 $P_D = C_{PD} \times V_{CC}^2 \times f_i + \sum (C_L \times V_{CC}^2 \times f_o)$ where:
 f_i = input frequency in MHz
 f_o = output frequency in MHz
 $\sum (C_L \times V_{CC}^2 \times f_o)$ = sum of outputs
 C_L = output load capacitance in pF
 V_{CC} = supply voltage in V
2. For HC the condition is $V_I = \text{GND to } V_{CC}$
 For HCT the condition is $V_I = \text{GND to } V_{CC} - 1.5\text{ V}$

ORDERING INFORMATION

See "[74HC/HCT/HCU/HCMOS Logic Package Information](#)".

8-input NAND gate

74HC/HCT30

PIN DESCRIPTION

PIN NO.	SYMBOL	NAME AND FUNCTION
1	A	data input
2	B	data input
3	C	data input
4	D	data input
5	E	data input
6	F	data input
7	GND	ground (0 V)
8	Y	data output
9, 10, 13	n.c.	not connected
11	G	data input
12	H	data input
14	V _{CC}	positive supply voltage

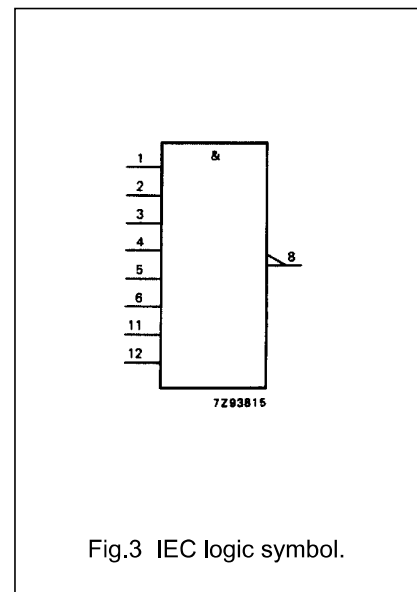
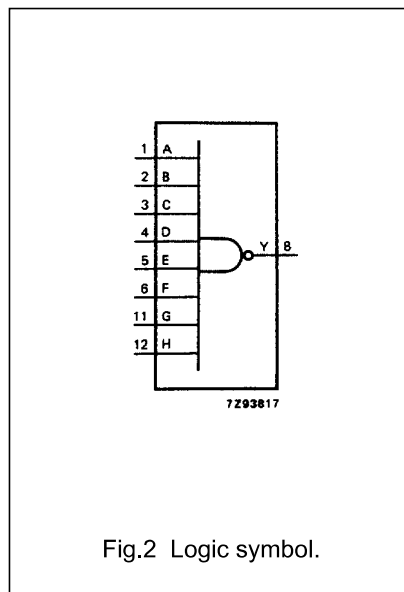
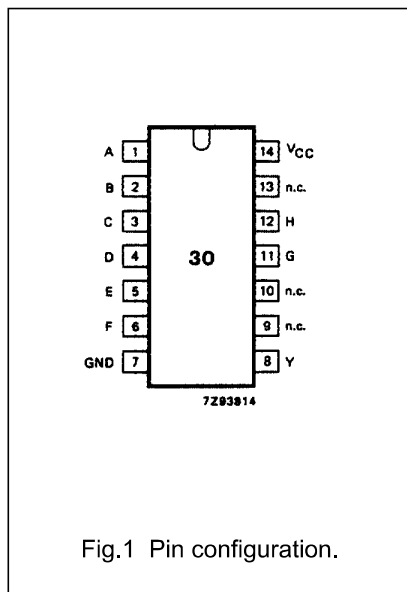

8-input NAND gate

74HC/HCT30

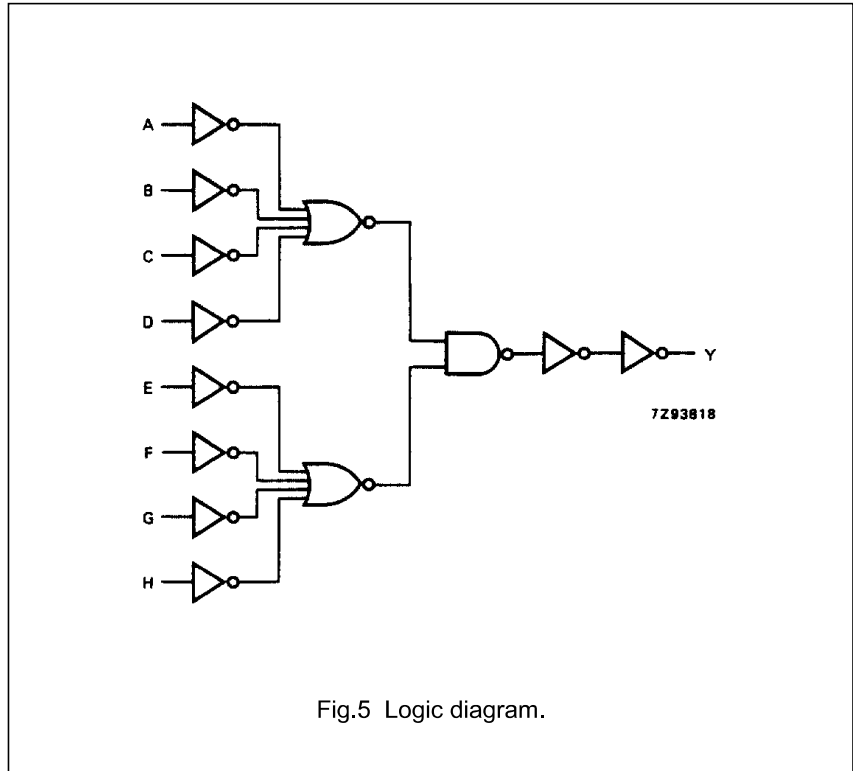
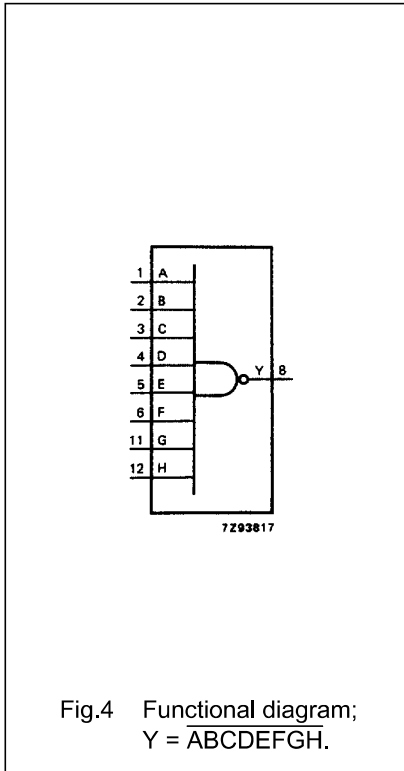

FUNCTION TABLE

INPUTS								OUTPUT
A	B	C	D	E	F	G	H	Y
L	X	X	X	X	X	X	X	H
X	L	X	X	X	X	X	X	H
X	X	L	X	X	X	X	X	H
X	X	X	L	X	X	X	X	H
X	X	X	X	L	X	X	X	H
X	X	X	X	X	L	X	X	H
X	X	X	X	X	X	L	X	H
X	X	X	X	X	X	X	L	H
H	H	H	H	H	H	H	H	L

Notes

1. H = HIGH voltage level
 L = LOW voltage level
 X = don't care

8-input NAND gate

74HC/HCT30

DC CHARACTERISTICS FOR 74 HC

For the DC characteristics see *"74HC/HCT/HCU/HCMOS Logic Family Specifications"*.

Output capability: standard

I_{CC} category: SSI

AC CHARACTERISTICS FOR 74HC

GND = 0 V; t_r = t_f = 6 ns; C_L = 50 pF

SYMBOL	PARAMETER	T _{amb} (°C)						UNIT	TEST CONDITIONS		
		74HC							V _{CC} (V)	WAVEFORMS	
		+25			-40 to +85		-40 to +125				
		min.	typ.	max.	min.	max.	min.				max.
t _{PHL} / t _{PLH}	propagation delay A, B, C, D, E, F, G, H to Y		41 15 12	130 26 22		165 33 28	195 39 33	ns	2.0 4.5 6.0	Fig.6	
t _{THL} / t _{TLH}	output transition time		19 7 6	75 15 13		95 19 16	110 22 19	ns	2.0 4.5 6.0	Fig.6	

DC CHARACTERISTICS FOR 74HCT

For the DC characteristics see *"74HC/HCT/HCU/HCMOS Logic Family Specifications"*.

Output capability: standard

I_{CC} category: SSI

Note to HCT types

The value of additional quiescent supply current (ΔI_{CC}) for a unit load of 1 is given in the family specifications.

To determine ΔI_{CC} per input, multiply this value by the unit load coefficient shown in the table below.

INPUT	UNIT LOAD COEFFICIENT
A, B, C, D, E, F, G, H	0.60

AC CHARACTERISTICS FOR 74HCT

GND = 0 V; t_r = t_f = 6 ns; C_L = 50 pF

SYMBOL	PARAMETER	T _{amb} (°C)						UNIT	TEST CONDITIONS		
		74HCT							V _{CC} (V)	WAVEFORMS	
		+25			-40 to +85		-40 to +125				
		min.	typ.	max.	min.	max.	min.				max.
t _{PHL} / t _{PLH}	propagation delay A, B, C, D, E, F, G, H to Y		16	28		35	42	ns	4.5	Fig.6	
t _{THL} / t _{TLH}	output transition time		7	15		19	22	ns	4.5	Fig.6	

8-input NAND gate

74HC/HCT30

AC WAVEFORMS

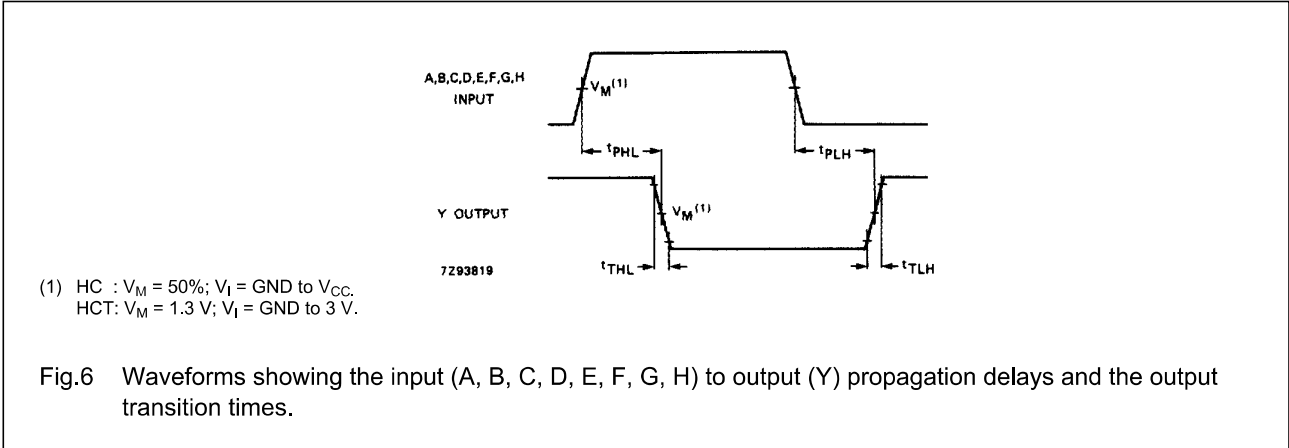

PACKAGE OUTLINES

See "74HC/HCT/HCU/HCMOS Logic Package Outlines".