

**4-BIT D-TYPE LATCH**

- HIGH SPEED  
 $t_{PD} = 15 \text{ ns (TYP.)}$  at  $V_{CC} = 5V$
- LOW POWER DISSIPATION  
 $I_{CC} = 2 \mu\text{A (MAX.)}$  at  $T_A = 25^\circ\text{C}$
- HIGH NOISE IMMUNITY  
 $V_{NIH} = V_{NIL} = 28\% V_{CC}$  (MIN.)
- OUTPUT DRIVE CAPABILITY  
10 LSTTL LOADS
- SYMMETRICAL OUTPUT IMPEDANCE  
 $|I_{OH}| = I_{OL} = 4 \text{ mA (MIN.)}$
- BALANCED PROPAGATION DELAYS  
 $t_{PLH} = t_{PHL}$
- WIDE OPERATING VOLTAGE RANGE  
 $V_{CC}$  (OPR) = 2V to 6V
- PIN AND FUNCTION COMPATIBLE  
WITH 54/74LS75

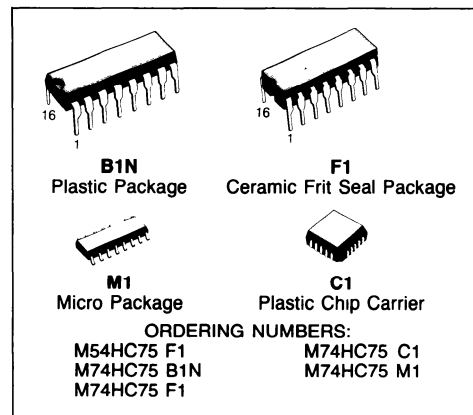

**DESCRIPTION**

The M54/74HC75 is a high speed CMOS 4-BIT D-TYPE LATCH fabricated in silicon gate C<sup>2</sup>MOS technology. It has the same high speed performance of LSTTL combined with true CMOS low power consumption. It contains two groups of 2-bit latches controlled by an enable input (G1 - 2 or G3 - 4). These two latch groups can be used in different circuits. Each latch has Q and  $\bar{Q}$  outputs (1Q - 4Q and  $1\bar{Q}$  -  $4\bar{Q}$ ). The data applied to the data input is transferred to the Q and  $\bar{Q}$  outputs when the enable input is taken high and the outputs will follow the data input as long as the enable input is kept high. When the enable input is taken low, the information data applied to the data input is retained at the outputs. All inputs are equipped with protection circuits against static discharge and transient excess voltage.

**TRUTH TABLE**

INPUTS		OUTPUTS		FUNCTION
D	G	Q	$\bar{Q}$	
L	H	L	H	—
H	H	H	L	—
X	L	Qn	$\bar{Q}n$	LATCH

X: DON'T CARE

**PIN CONNECTIONS (top view)**

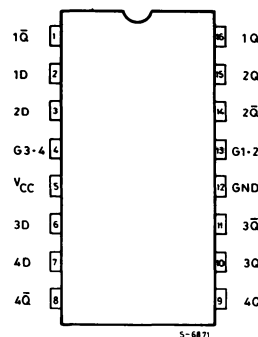

FOR CHIP CARRIER  
INFORMATION CONTACT SGS-THOMSON

## M54/74HC75

### LOGIC DIAGRAM

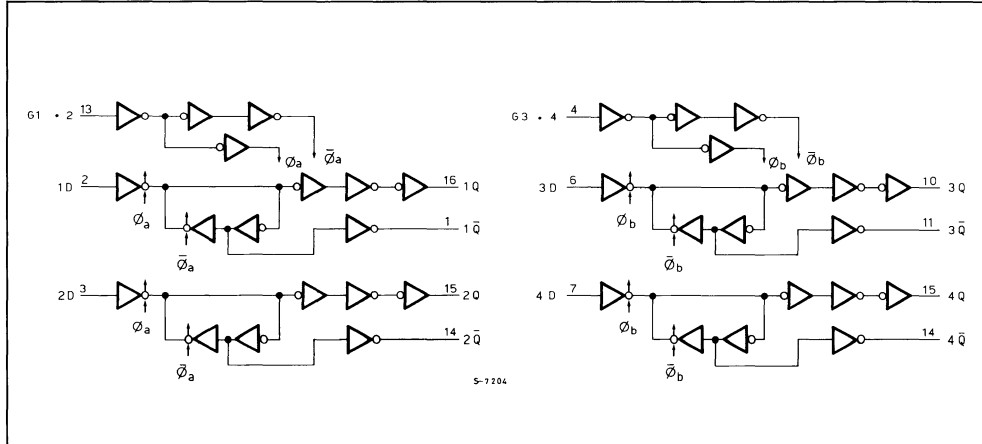

### ABSOLUTE MAXIMUM RATINGS

Symbol	Parameter	Value	Unit
$V_{CC}$	Supply Voltage	-0.5 to 7	V
$V_I$	DC Input Voltage	-0.5 to $V_{CC} + 0.5$	V
$V_O$	DC Output Voltage	-0.5 to $V_{CC} + 0.5$	V
$I_{IK}$	DC Input Diode Current	$\pm 20$	mA
$I_{OK}$	DC Output Diode Current	$\pm 20$	mA
$I_O$	DC Output Source Sink Current Per Output Pin	$\pm 25$	mA
$I_{CC}$ or $I_{GND}$	DC $V_{CC}$ or Ground Current	$\pm 50$	mA
$P_D$	Power Dissipation	500 (*)	mW
$T_{stg}$	Storage Temperature	-65 to 150	$^{\circ}C$

Absolute Maximum Ratings are those values beyond which damage to the device may occur. Functional operation under these condition is not implied.

(\*) 500 mW:  $\cong 65^{\circ}C$  derate to 300 mW by 10 mW/ $^{\circ}C$ :  $65^{\circ}C$  to  $85^{\circ}C$

### RECOMMENDED OPERATING CONDITIONS

Symbol	Parameter	Value	Unit
$V_{CC}$	Supply Voltage	2 to 6	V
$V_I$	Input Voltage	0 to $V_{CC}$	V
$V_O$	Output Voltage	0 to $V_{CC}$	V
$T_A$	Operating Temperature	74HC Series 54HC Series	$^{\circ}C$
		- 40 to 85 - 55 to 125	
$t_r, t_f$	Input Rise and Fall Time	$V_{CC} \begin{cases} 2 \text{ V} & 0 \text{ to } 1000 \\ 4.5 \text{ V} & 0 \text{ to } 500 \\ 6 \text{ V} & 0 \text{ to } 400 \end{cases}$	ns

## DC SPECIFICATIONS

Symbol	Parameter	V <sub>CC</sub>	Test Condition	T <sub>A</sub> = 25°C 54HC and 74HC			- 40 to 85°C 74HC		- 55 to 125°C 54HC		Unit	
				Min.	Typ.	Max.	Min.	Max.	Min.	Max.		
V <sub>IH</sub>	High Level Input Voltage	2.0		1.5	—	—	1.5	—	1.5	—	V	
		4.5		3.15	—	—	3.15	—	3.15	—		
		6.0		4.2	—	—	4.2	—	4.2	—		
V <sub>IL</sub>	Low Level Input Voltage	2.0		—	—	0.5	—	0.5	—	0.5	V	
		4.5		—	—	1.35	—	1.35	—	1.35		
		6.0		—	—	1.8	—	1.8	—	1.8		
V <sub>OH</sub>	High Level Output Voltage	2.0	V <sub>I</sub>	I <sub>O</sub>	1.9	2.0	—	1.9	—	1.9	V	
		4.5	V <sub>IH</sub> or V <sub>IL</sub>	- 20 μA	4.4	4.5	—	4.4	—	4.4		
		6.0			5.9	6.0	—	5.9	—	5.9		
		4.5		- 4.0 mA	4.18	4.31	—	4.13	—	4.10		
6.0		- 5.2 mA	5.68	5.8	—	5.63	—	5.60				
V <sub>OL</sub>	Low Level Output Voltage	2.0	V <sub>IH</sub> or V <sub>IL</sub>	20 μA	—	0	0.1	—	0.1	—	0.1	V
		4.5		—	0	0.1	—	0.1	—	0.1		
		6.0		—	0	0.1	—	0.1	—	0.1		
		4.5		4.0 mA	—	0.17	0.26	—	0.33	—	0.40	
6.0	5.2 mA	—	0.18	0.26	—	0.33	—	0.40				
I <sub>I</sub>	Input Leakage Current	6.0	V <sub>I</sub> = V <sub>CC</sub> or GND	—	—	±0.1	—	±1	—	±1	μA	
I <sub>CC</sub>	Quiescent Supply Current	6.0	V <sub>I</sub> = V <sub>CC</sub> or GND	—	—	2	—	20	—	40	μA	

AC ELECTRICAL CHARACTERISTICS (V<sub>CC</sub> = 5V, T<sub>A</sub> = 25°C, C<sub>L</sub> = 15pF, Input t<sub>r</sub> = t<sub>f</sub> = 6ns)

Symbol	Parameter	54HC and 74HC			Unit
		Min.	Typ.	Max.	
t <sub>TLH</sub> t <sub>THL</sub>	Output Transition Time		4	8	ns
t <sub>PLH</sub> t <sub>PHL</sub>	Propagation Delay Time (DATA-Q, Q)		12	20	ns
t <sub>PLH</sub> t <sub>PHL</sub>	Propagation Delay Time (G-Q, Q̄)		15	25	ns

## M54/74HC75

### AC ELECTRICAL CHARACTERISTICS ( $C_L = 50\text{pF}$ , Input $t_r = t_f = 6\text{ns}$ )

Symbol	Parameter	$V_{CC}$	Test Condition	$T_A = 25^\circ\text{C}$ 54HC and 74HC			$-40$ to $85^\circ\text{C}$ 74HC		$-55$ to $125^\circ\text{C}$ 54HC		Unit
				Min.	Typ.	Max.	Min.	Max.	Min.	Max.	
$t_{TLH}$ $T_{THL}$	Output Transition Time	2.0 4.5 6.0		— — —	30 8 7	75 15 13	— — —	95 19 16	— — —	110 22 19	ns
$t_{PLH}$ $t_{PHL}$	Propagation Delay Time (DATA-Q, $\bar{Q}$ )	2.0 4.5 6.0		— — —	60 15 13	120 24 20	— — —	150 30 26	— — —	180 36 31	ns
$t_{PLH}$ $t_{PHL}$	Propagation Delay Time (G-Q, $\bar{Q}$ )	2.0 4.5 6.0		— — —	76 19 16	145 29 25	— — —	180 36 31	— — —	218 44 38	ns
$t_{W(H)}$	Minimum Pulse Width (G)	2.0 4.5 6.0		— — —	30 8 7	75 15 13	— — —	95 19 16	— — —	110 22 19	ns
$t_s$	Minimum Set-Up Time	2.0 4.5 6.0		— — —	5 1 1	50 10 9	— — —	65 13 11	— — —	75 15 13	ns
$t_h$	Minimum Hold Time	2.0 4.5 6.0		— — —	— — —	25 5 5	— — —	30 6 6	— — —	40 8 7	ns
$C_{IN}$	Input Capacitance			—	5	10	—	10	—	10	pF
$C_{PD} (*)$	Power Dissipation Capacitance			—	48	—	—	—	—	—	pF

Note (\*)  $C_{PD}$  is defined as the value of the IC's internal equivalent capacitance which is calculated from the operating current consumption without load.

### SWITCHING CHARACTERISTICS TEST CIRCUIT

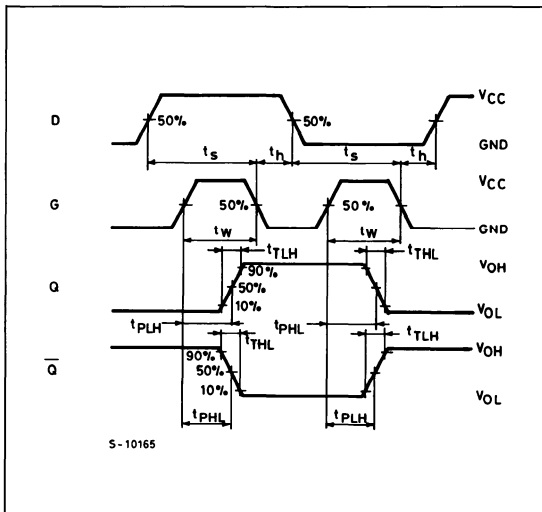

### TEST CIRCUIT $I_{CC}$ (Opr)

