

Quad Two-Input NOR Gate

TYPE	TYPICAL PROPAGATION DELAY	TYPICAL SUPPLY CURRENT (Total)
7402	10ns	11mA
74LS02	10ns	2.2mA
74S02	3.5ns	22mA

ORDERING CODE

PACKAGES	COMMERCIAL RANGES	MILITARY RANGES
	$V_{CC} = 5V \pm 5\%; T_A = 0^\circ C \text{ to } +70^\circ C$	$V_{CC} = 5V \pm 10\%; T_A = -55^\circ C \text{ to } +125^\circ C$
Plastic DIP	N7402N • N74LS02N N74S02N	
Plastic SO	N74LS02D • N74S02D	
Ceramic DIP		S54S02F • S54LS02F
Flatpack		S54S02W • S54LS02W
LLCC		S54LS02G

FUNCTION TABLE

INPUTS		OUTPUT
A	B	Y
L	L	H
L	H	L
H	L	L
H	H	L

H = HIGH voltage level
L = LOW voltage level

INPUT AND OUTPUT LOADING AND FAN-OUT TABLE

PINS	DESCRIPTION	54/74	54/74S	54/74LS
A, B	Inputs	1ul	1Sul	1LSul
Y	Output	10ul	10Sul	10LSul

NOTE
Where a 54/74 unit load (ul) is understood to be 40µA I_{IH} and -1.6mA I_{IL} , a 54/74S unit load (Sul) is 50µA I_{IH} and -2.0mA I_{IL} , and 54/74LS unit load (LSul) is 20µA I_{IH} and -0.4mA I_{IL} .

PIN CONFIGURATION

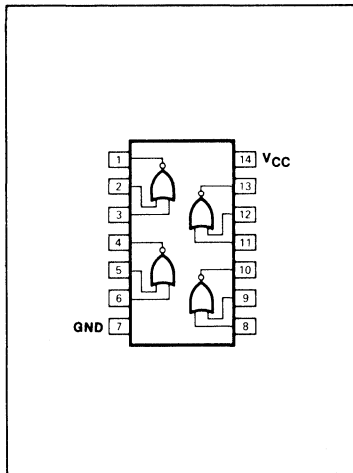

LOGIC SYMBOL

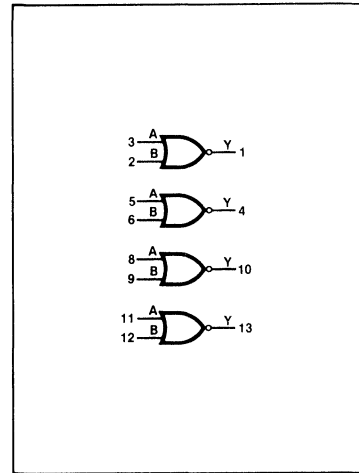

LOGIC SYMBOL (IEEE/IEC)

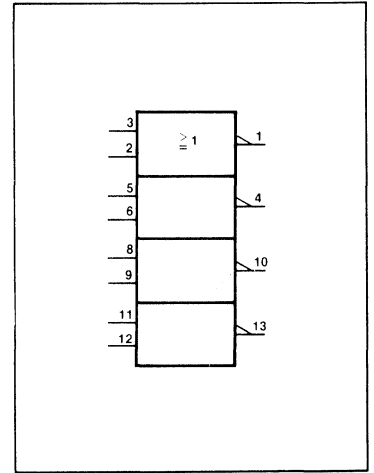

ABSOLUTE MAXIMUM RATINGS (Over operating free-air temperature range unless otherwise noted.)

PARAMETER	54	54LS	54S	74	74LS	74S	UNIT
V _{CC} Supply voltage	7.0	7.0	7.0	7.0	7.0	7.0	V
V _{IN} Input voltage	-0.5 to +5.5	-0.5 to +7.0	-0.5 to +5.5	-0.5 to +5.5	-0.5 to +7.0	-0.5 to +5.5	V
I _{IN} Input current	-30 to +5	-30 to +1	-30 to +5	-30 to +5	-30 to +1	-30 to +5	mA
V _{OUT} Voltage applied to output in HIGH output state	-0.5 to +V _{CC}	-0.5 to +V _{CC}	-0.5 to +V _{CC}	-0.5 to +V _{CC}	-0.5 to +V _{CC}	-0.5 to +V _{CC}	V
T _A Operating free-air temperature range	-55 to +125			0 to 70			°C

RECOMMENDED OPERATING CONDITIONS

PARAMETER		54/74			54/74LS			54/74S			UNIT
		Min	Nom	Max	Min	Nom	Max	Min	Nom	Max	
V _{CC} Supply voltage	Mil	4.5	5.0	5.5	4.5	5.0	5.5	4.5	5.0	5.5	V
	Com'l	4.75	5.0	5.25	4.75	5.0	5.25	4.75	5.0	5.25	V
V _{IH} HIGH-level input voltage		2.0			2.0			2.0			V
V _{IL} LOW-level input voltage	Mil			÷0.8			+0.7			+0.8	V
	Com'l			+0.8			+0.8			+0.8	V
I _{IK} Input clamp current				-12			-18			-18	mA
I _{OH} HIGH-level output current				-400			-400			-1000	µA
I _{OL} LOW-level output current	Mil			16			4			20	mA
	Com'l			16			8			20	mA
T _A Operating free-air temperature	Mil	-55		+125	-55		+125	-55		+125	°C
	Com'l	0		70	0		70	0		70	°C

NOTE
V_{IL} = +0.7V MAX for 54S at T_A = +125°C only.

TEST CIRCUITS AND WAVEFORMS

TEST CIRCUIT FOR 54/74 TOTEM-POLE OUTPUTS

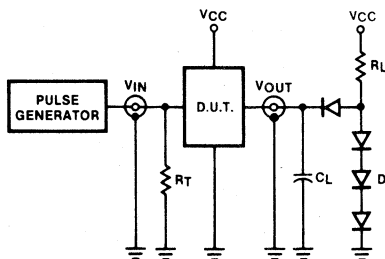

DEFINITIONS

R_L = Load resistor to V_{CC}; see AC CHARACTERISTICS for value.
 C_L = Load capacitance includes jig and probe capacitance; see AC CHARACTERISTICS for value.
 R_T = Termination resistance should be equal to Z_{OUT} of Pulse Generators.
 D = Diodes are 1N916, 1N3064, or equivalent.
 t_{TLH}, t_{THL} Values should be less than or equal to the table entries.

INPUT PULSE DEFINITIONS

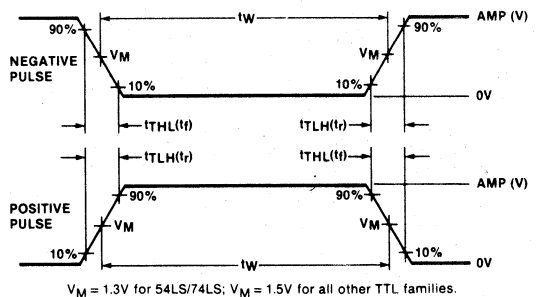

FAMILY	INPUT PULSE REQUIREMENTS				
	Amplitude	Rep. Rate	Pulse Width	t _{TLH}	t _{TTL}
54/74	3.0V	1MHz	500ns	7ns	7ns
54LS/74LS	3.0V	1MHz	500ns	15ns	6ns
54S/74S	3.0V	1MHz	500ns	2.5ns	2.5ns

DC ELECTRICAL CHARACTERISTICS (Over recommended operating free-air temperature range unless otherwise noted.)

PARAMETER	TEST CONDITIONS ¹	54/7402			54/74LS02			54/74S02			UNIT	
		Min	Typ ²	Max	Min	Typ ²	Max	Min	Typ ²	Max		
V _{OH} HIGH-level output voltage	V _{CC} = MIN, V _{IL} = MAX, I _{OH} = MAX	Mil	2.4	3.4		2.5	3.4		2.5	3.4	V	
		Com'l	2.4	3.4		2.7	3.4		2.7	3.4	V	
V _{OL} LOW-level output voltage	V _{CC} = MIN, V _{IH} = MIN	Mil		0.2	0.4		0.25	0.4		0.5 ⁴	V	
		Com'l		0.2	0.4		0.35	0.5		0.5	V	
		I _{OL} = 4mA	74LS				0.25	0.4			V	
V _{IK} Input clamp voltage	V _{CC} = MIN, I _I = I _{IK}			-1.5			-1.5			-1.2	V	
I _I Input current at maximum input voltage	V _{CC} = MAX	V _I = 5.5V			1.0					1.0	mA	
		V _I = 7.0V					0.1				mA	
I _{IH} HIGH-level input current	V _{CC} = MAX	V _I = 2.4V		40							μA	
		V _I = 2.7V					20			50	μA	
I _{IL} LOW-level input current	V _{CC} = MAX	V _I = 0.4V		-1.6			-0.4				mA	
		V _I = 0.5V								-2.0	mA	
I _{OS} Short-circuit output current ³	V _{CC} = MAX	Mil	-20		-55	-20		-100	-40		-100	mA
		Com'l	-18		-55	-20		-100	-40		-100	mA
I _{CC} Supply Current (total)	V _{CC} = MAX	I _{CCH} Outputs HIGH		8	16		1.6	3.2		17	29	mA
		I _{CCL} Outputs LOW		14	27		2.8	5.4		26	45	mA

4

NOTES

- For conditions shown as MIN or MAX, use the appropriate value specified under recommended operating conditions for the applicable type.
- All typical values are at V_{CC} = 5V, T_A = 25°C.
- I_{OS} is tested with V_{OUT} = +0.5V and V_{CC} = V_{CC} MAX + 0.5V. Not more than one output should be shorted at a time and duration of the short circuit should not exceed one second.
- V_{OL} = +0.45V MAX for 54S at T_A = +125°C only.

AC WAVEFORM

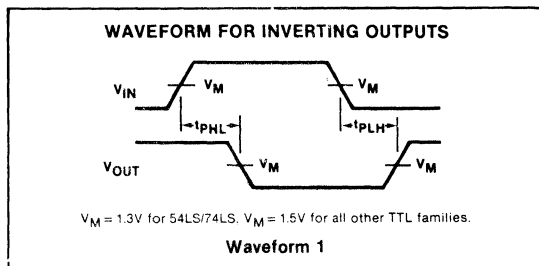

AC CHARACTERISTICS T_A = 25°C, V_{CC} = 5.0V

PARAMETER	TEST CONDITIONS	54/74		54/74LS		54/74S		UNIT
		C _L = 15pF, R _L = 400Ω		C _L = 15pF, R _L = 2kΩ		C _L = 15pF, R _L = 280Ω		
		Min	Max	Min	Max	Min	Max	
t _{PLH} t _{PHL} Propagation delay	Waveform 1		22 15		15 15		5.5 5.5	ns