



54LS249/DM74LS249 BCD to 7-Segment Decoder (with Open-Collector Outputs)

General Description

The 'LS249 has active HIGH open-collector outputs and incorporates the Lamp Test and $\overline{\text{BI/RBO}}$ inputs. Additionally, the 'LS249 will light the top bar (segment a) for numeral 6 and the bottom bar (segment d) for numeral 9.

Connection Diagram

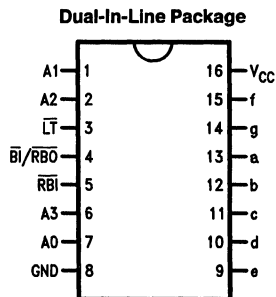

TL/F/10213-1

Order Number 54LS249DMBQ, 54LS249FMBQ or
DM74LS249N

See NS Package Number J16A, N16E or W16A

Logic Symbol

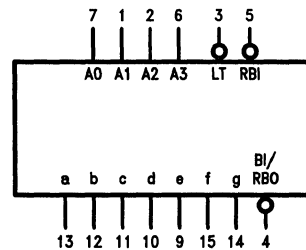

V_{CC} = Pin 16
GND = Pin 8

TL/F/10213-2

Pin Names	Description
A ₀ -A ₃	BCD Inputs
$\overline{\text{BI}}$	Blanking Input (Active LOW)
$\overline{\text{LT}}$	Lamp Test Input (Active LOW)
$\overline{\text{BI/RBO}}$	Blanking Input (Active LOW) or Ripple Blanking Output (Active LOW)
a-g	Segment Outputs (Active HIGH)

Absolute Maximum Ratings (Note)

If Military/Aerospace specified devices are required, please contact the National Semiconductor Sales Office/Distributors for availability and specifications.

Supply Voltage	7V
Input Voltage	7V
Operating Free Air Temperature Range	
54LS	–55°C to +125°C
DM74LS	0°C to +70°C
Storage Temperature Range	–65°C to +150°C

Note: The "Absolute Maximum Ratings" are those values beyond which the safety of the device cannot be guaranteed. The device should not be operated at these limits. The parametric values defined in the "Electrical Characteristics" table are not guaranteed at the absolute maximum ratings. The "Recommended Operating Conditions" table will define the conditions for actual device operation.

Recommended Operating Conditions

Symbol	Parameter	54LS249			DM74LS249			Units
		Min	Nom	Max	Min	Nom	Max	
V _{CC}	Supply Voltage	4.5	5	5.5	4.75	5	5.25	V
V _{IH}	High Level Input Voltage	2			2			V
V _{IL}	Low Level Input Voltage			0.7			0.8	V
I _{OH}	High Level Output Current			–0.25			–0.25	mA
I _{OL}	Low Level Output Current			4			8	mA
T _A	Free Air Operating Temperature	–55		125	0		70	°C

Electrical Characteristics over recommended operating free air temperature range (unless otherwise noted)

Symbol	Parameter	Conditions	Min	Typ (Note 1)	Max	Units
V _I	Input Clamp Voltage	V _{CC} = Min, I _I = –18 mA			–1.5	V
V _{OH}	High Level Output Voltage	V _{CC} = Min, I _{OH} = Max, V _{IL} = Max	54LS 2.4			V
			DM74 2.7	3.4		
V _{OL}	Low Level Output Voltage	V _{CC} = Min, I _{OL} = Max, V _{IH} = Min	54LS		0.4	V
			DM74	0.35	0.5	
		I _{OL} = 4 mA, V _{CC} = Min	DM74	0.25	0.4	
I _I	Input Current @ Max Input Voltage	V _{CC} = Max, V _I = 10V			0.1	mA
I _{IH}	High Level Input Current	V _{CC} = Max, V _I = 2.7V			20	μA
I _{IL}	Low Level Input Current	V _{CC} = Max, V _I = 0.4V	Inputs	–0.03	–0.4	mA
			BI/RB \bar{O}	–0.09	–1.2	
I _{OS}	Short Circuit Output Current	V _{CC} = Max (Note 2)	54LS	–0.3	–2.0	mA
			DM74	–20	–100	
I _{CC}	Supply Current	V _{CC} = Max, V _{IN} = 4.5V			15	mA

Note 1: All typicals are at V_{CC} = 5V, T_A = 25°C.

Note 2: Not more than one output should be shorted at a time, and the duration should not exceed one second.

Switching Characteristics

at $V_{CC} = +5.0V$, $T_A = +25^\circ C$ (See Section 1 for Test Waveforms and Output Load)

Symbol	Parameter	$R_L = 2\ k\Omega$		Units
		$C_L = 15\ pF$		
		Min	Max	
t_{PLH} t_{PHL}	Propagation Delay Time A_n to a-g ($54LS\ R_L = 2\ k\Omega$)		100 100	ns
t_{PLH} t_{PHL}	Propagation Delay Time \overline{BI} to a-g ($54LS\ R_L = 6\ k\Omega$)		100 100	ns

Numerical Designations—Resultant Displays

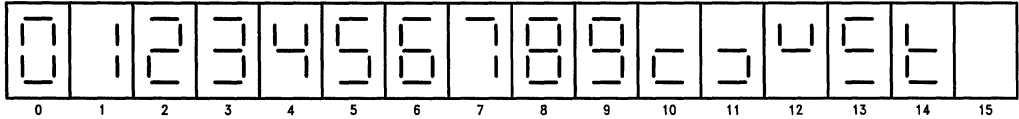

Truth Table

Decimal or Function	Inputs						Outputs							Note	
	\overline{LT}	A_3	A_2	A_1	A_0	$\overline{BI/RBO}$	a	b	c	d	e	f	g		
0	H	L	L	L	L	H	H	H	H	H	H	H	L	L	1
1	H	L	L	L	L	H	L	H	H	L	L	L	L	L	1
2	H	L	L	H	L	H	H	H	L	H	H	L	H		
3	H	L	L	H	H	H	H	H	H	H	L	L	H		
4	H	L	H	L	L	H	L	H	H	L	L	H	H		
5	H	L	H	L	H	H	H	L	H	H	L	H	H		
6	H	L	H	H	L	H	L	L	H	H	H	H	H		
7	H	L	H	H	H	H	H	H	H	L	L	L	L		
8	H	H	L	L	L	H	H	H	H	H	H	H	H		
9	H	H	L	L	H	H	H	H	H	L	L	H	H		
10	H	H	L	H	L	H	L	L	L	H	H	L	H		
11	H	H	L	H	H	H	L	L	H	H	L	L	H		
12	H	H	H	L	L	H	L	H	L	L	L	H	H		
13	H	H	H	L	H	H	H	L	L	H	L	H	H		
14	H	H	H	H	L	H	L	L	L	H	H	H	H		
15	H	H	H	H	H	H	L	L	L	L	L	L	L		
\overline{BI}	X	X	X	X	X	L	L	L	L	L	L	L	L	2	
\overline{LT}	L	X	X	X	X	H	H	H	H	H	H	H	H	3	

Note 1: $\overline{BI/RBO}$ is wired-AND logic serving as blanking input (\overline{BI}) and/or ripple-blanking output (\overline{RBO}). The blanking out (\overline{BI}) must be open or held at a HIGH level when output functions 0 through 15 are desired. X = input may be HIGH or LOW.

Note 2: When a LOW level is applied to the blanking input (forced condition) all segment outputs go to a LOW level, regardless of the state of any other input condition.

Note 3: When the blanking input/ripple-blanking output ($\overline{BI/RBO}$) is open or held at a HIGH level, and a LOW level is applied to lamp test input, all segment outputs go to a HIGH level.

Logic Diagram

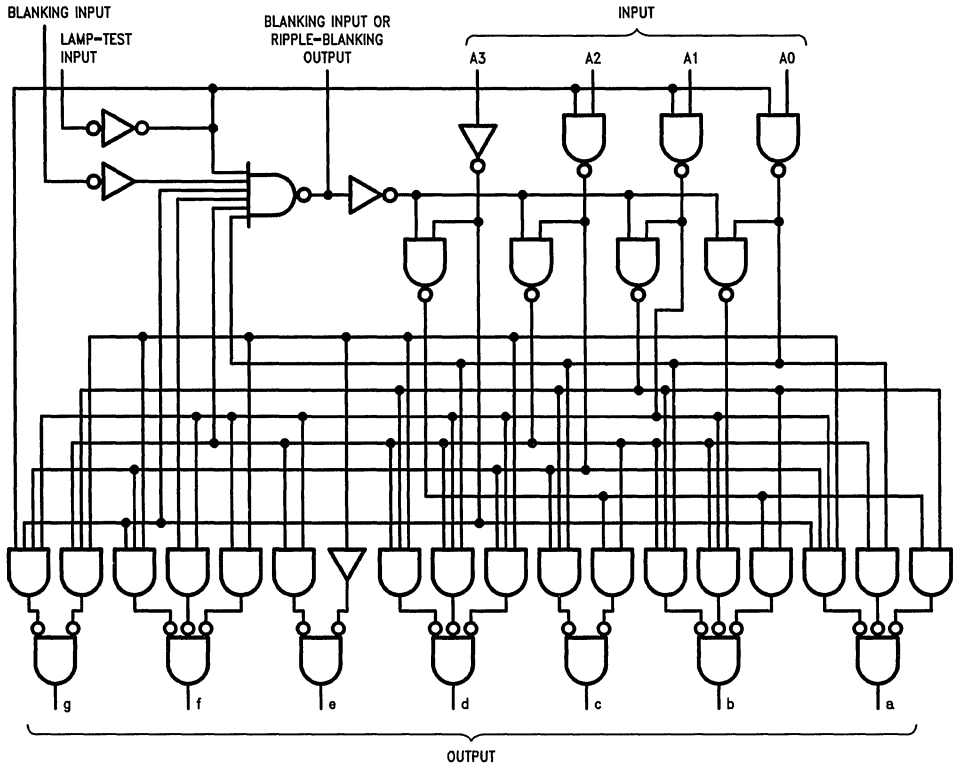

TL/F/10213-4