

# SN54LS261, SN74LS261 2-BIT BY 4-BIT PARALLEL BINARY MULTIPLIERS

MARCH 1974 — REVISED MARCH 1988

- Fast Multiplication . . . 5-Bit Product in 26 ns Typ
- Power Dissipation . . . 110 mW Typical
- Latch Outputs for Synchronous Operation
- Expandable for m-Bit-by-n-Bit Applications
- Fully Compatible with Most TTL and Other Saturated Low-Level Logic Families
- Diode-Clamped Inputs Simplify System Design

SN54LS261 . . . J OR W PACKAGE  
SN74LS261 . . . D OR N PACKAGE

(TOP VIEW)

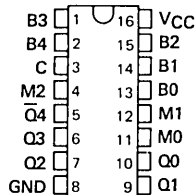

SN54LS261 . . . FK PACKAGE  
(TOP VIEW)

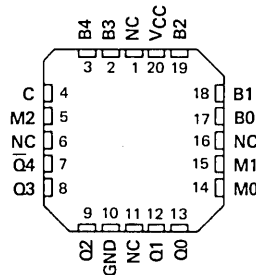

NC - No internal connection

FUNCTION TABLE

LATCH CONTROL C	INPUTS			OUTPUTS				
	M2	M1	M0	$\bar{Q}_4$	Q <sub>3</sub>	Q <sub>2</sub>	Q <sub>1</sub>	Q <sub>0</sub>
L	X	X	X	$\bar{Q}_4$	Q <sub>3</sub>	Q <sub>2</sub>	Q <sub>1</sub>	Q <sub>0</sub>
H	L	L	L	H	L	L	L	L
H	L	L	H	$\bar{B}_4$	B <sub>4</sub>	B <sub>3</sub>	B <sub>2</sub>	B <sub>1</sub>
H	L	H	L	$\bar{B}_4$	B <sub>4</sub>	B <sub>3</sub>	B <sub>2</sub>	B <sub>1</sub>
H	L	H	H	$\bar{B}_4$	B <sub>3</sub>	B <sub>2</sub>	B <sub>1</sub>	B <sub>0</sub>
H	H	L	L	B <sub>4</sub>	$\bar{B}_3$	$\bar{B}_2$	$\bar{B}_1$	$\bar{B}_0$
H	H	L	H	B <sub>4</sub>	$\bar{B}_4$	$\bar{B}_3$	$\bar{B}_2$	$\bar{B}_1$
H	H	H	L	B <sub>4</sub>	B <sub>4</sub>	$\bar{B}_3$	$\bar{B}_2$	$\bar{B}_1$
H	H	H	H	H	L	L	L	L

H = high level, L = low level, X = irrelevant  
 $\bar{Q}_4 \dots Q_0$  = The logic level of the same output before the high-to-low transition of C.  
 B<sub>4</sub> . . . B<sub>0</sub> = The logic level of the indicated multiplicand (B) input.

## description

These low-power Schottky circuits are designed to be used in parallel multiplication applications. They perform binary multiplication in two's-complement form, two bits at a time.

The M inputs are for the multiplier bits and the B inputs are for the multiplicand. The Q outputs represent the partial product as a recoded base-4 number. This recoding effectively reduces the Wallace-tree hardware requirements by a factor of two.

The outputs represent partial products in one's-complement form generated as a result of multiplication. A simple rounding scheme using two additional gates is needed for each partial product to generate two's complement.

The leading (most-significant) bit of the product is inverted for ease in extending the sign to square (left justify) the partial-product bits.

The SN54LS261 is characterized for operation over the full military temperature range of  $-55^\circ\text{C}$  to  $125^\circ\text{C}$ ; the SN74LS261 for operation from  $0^\circ\text{C}$  to  $70^\circ\text{C}$ .

## logic symbol†

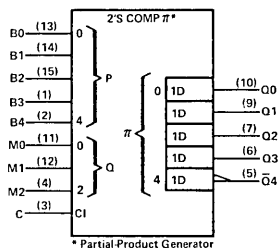

†This symbol is in accordance with ANSI/IEEE Std. 91-1984 and IEC Publication 617-12.

Pin numbers shown are for D, J, N, and W packages.

PRODUCTION DATA documents contain information current as of publication date. Products conform to specifications per the terms of Texas Instruments standard warranty. Production processing does not necessarily include testing of all parameters.

TEXAS  
INSTRUMENTS

POST OFFICE BOX 655012 • DALLAS, TEXAS 75265

2-743

2  
TTL Devices

**SN54LS261, SN74LS261**  
**2-BIT BY 4-BIT PARALLEL BINARY MULTIPLIERS**

schematics of inputs and outputs

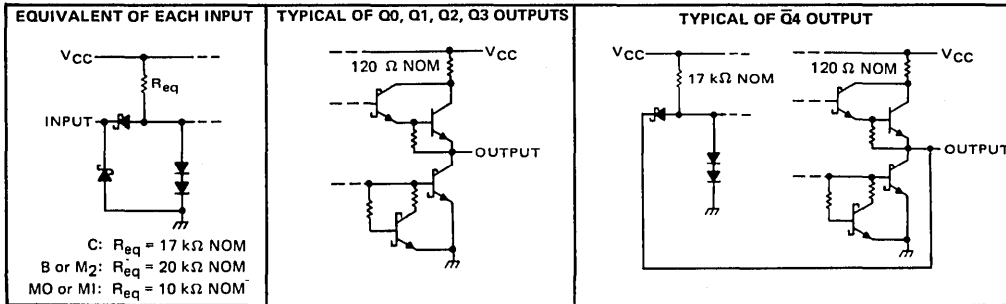

logic diagram (positive logic)

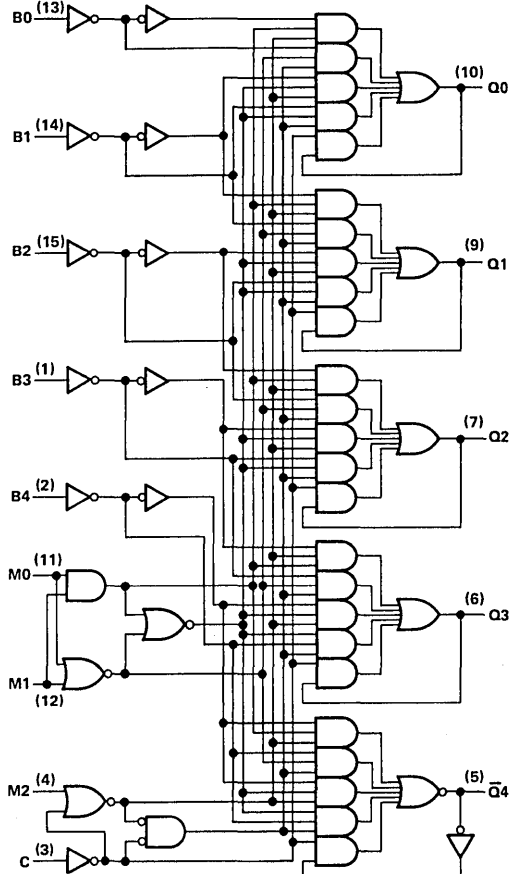

Pin numbers shown are for D, J, N, and W packages.

**2**  
**TTL Devices**

## SN54LS261, SN74LS261 2-BIT BY 4-BIT PARALLEL BINARY MULTIPLIERS

### absolute maximum ratings over operating free-air temperature range (unless otherwise noted)

Supply voltage, $V_{CC}$ (see Note 1)	7 V
Input voltage	7 V
Operating free-air temperature range: SN54LS261	-55°C to 125°C
SN74LS261	0°C to 70°C
Storage temperature range	-65°C to 150°C

NOTE 1: Voltage values are with respect to network ground terminal.

### recommended operating conditions

	SN54LS261			SN74LS261			UNIT
	MIN	NOM	MAX	MIN	NOM	MAX	
Supply voltage, $V_{CC}$	4.5	5	5.5	4.75	5	5.25	V
High-level output current, $I_{OH}$			-400			-400	$\mu$ A
Low-level output current, $I_{OL}$			4			8	mA
Width of enable pulse, $t_w$		25			25		ns
Setup time, $t_{SU}$	Any M input	17		17			ns
	Any B input	15		15			
Hold time, $t_H$	Any M input	0		0			ns
	Any B input	0		0			
Operating free-air temperature, $T_A$		-55	125		0	70	°C

†The arrow indicates that the falling edge of the enable pulse is used for reference.

### electrical characteristics over recommended operating free-air temperature range (unless otherwise noted)

PARAMETER	TEST CONDITIONS†	SN54LS261			SN74LS261			UNIT
		MIN	TYP‡	MAX	MIN	TYP‡	MAX	
$V_{IH}$ High-level input voltage		2			2			V
$V_{IL}$ Low-level input voltage				0.7			0.8	V
$V_{IK}$ Input clamp voltage	$V_{CC} = \text{MIN}$ , $I_I = -18 \text{ mA}$			-1.5			-1.5	V
$V_{OH}$ High-level output voltage	$V_{CC} = \text{MIN}$ , $V_{IH} = 2 \text{ V}$ , $V_{IL} = V_{IL \text{ max}}$ , $I_{OH} = -400 \mu\text{A}$	2.5	3.4		2.7	3.4		V
$V_{OL}$ Low-level output voltage	$V_{CC} = \text{MIN}$ , $V_{IH} = 2 \text{ V}$ , $V_{IL} = V_{IL \text{ max}}$	$I_{OL} = 4 \text{ mA}$	0.25	0.4	0.25	0.4		V
		$I_{OL} = 8 \text{ mA}$			0.35	0.5		
$I_I$ Input current at maximum input voltage	$V_{CC} = \text{MAX}$ , $V_I = 7 \text{ V}$	MO or MI		0.2		0.2		mA
		All others		0.1		0.1		
$I_{IH}$ High-level input current	$V_{CC} = \text{MAX}$ , $V_I = 2.7 \text{ V}$	MO or MI		40		40		$\mu$ A
		All others		20		20		
$I_{IL}$ Low-level input current	$V_{CC} = \text{MAX}$ , $V_I = 0.4 \text{ V}$	MO or MI		-0.8		-0.8		mA
		All others		-0.4		-0.4		
$I_{OS}$ Short-circuit output current §	$V_{CC} = \text{MAX}$			-20		-100		mA
$I_{CC}$ Supply current	$V_{CC} = \text{MAX}$ , All inputs at 0 V, Outputs open.		20	38		20	40	mA

†For conditioning shown as MIN or MAX, use the appropriate value specified under recommended operating conditions.

‡All typical values are at  $V_{CC} = 5 \text{ V}$ ,  $T_A = 25^\circ\text{C}$ .

§Not more than one output should be shorted at a time and duration of the output short-circuit should not exceed one second.

2  
TTL Devices



**SN54LS261, SN74LS261**  
**2-BIT BY 4-BIT PARALLEL BINARY MULTIPLIERS**

switching characteristics,  $V_{CC} = 5\text{ V}$ ,  $T_A = 25^\circ\text{C}$

PARAMETER <sup>†</sup>	FROM (INPUT)	TO (OUTPUT)	TEST CONDITIONS	MIN	TYP	MAX	UNIT
$t_{PLH}$	C	Any Q	$C_L = 15\text{ pF}$ , $R_L = 2\text{ k}\Omega$ , See Note 2	22	35	ns	
$t_{PHL}$				20	30	ns	
$t_{PLH}$	Any M input	Any Q		25	40	ns	
$t_{PHL}$				22	35	ns	
$t_{PLH}$	Any B input	Any Q		27	42	ns	
$t_{PHL}$				24	37	ns	

<sup>†</sup> $t_{PLH}$  = propagation delay time, low-to-high-level output;  $t_{PHL}$  = propagation delay time, high-to-low-level output  
 NOTE 2: Load circuits and voltage waveforms are shown in Section 1.

**TYPICAL APPLICATION DATA**

**2**  
TTL Devices

Multiplication of the numbers 26 (multiplicand) by 29 (multiplier) in decimal, binary, and 2-bit-at-a-time-binary is shown here:

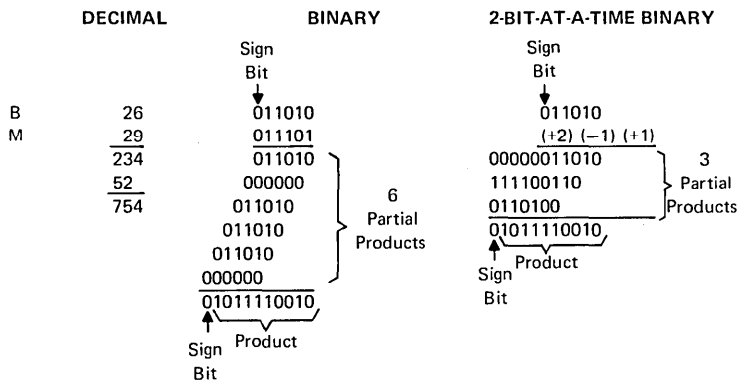

Two points should be noted in the two-bit-at-a-time-binary example above. First, in positioning the partial products beneath each other for final addition, each partial product is shifted two places to the left of the partial products above it instead of one place as is done in regular multiplication. Second, the msb of the partial product (the sign bit) is extended to the sign-bit column of the final answer.

A substantial reduction of multiplication time, cost, and power is obtained by implementing a parallel partial-product-generation scheme using a 2-bit-at-a-time algorithm, followed by a Wallace Tree summation.

Partial-product-generation rules of the algorithm are:

1. Examine two bits of multiplier M plus the next lower bit. For the first partial product (PP1) the next lower bit is zero.

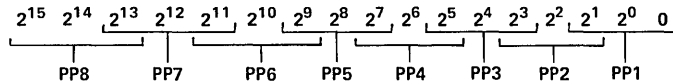

**SN54LS261, SN74LS261**  
**2-BIT BY 4-BIT PARALLEL BINARY MULTIPLIERS**

**TYPICAL APPLICATION DATA**

2. Generate partial product (PPi) as shown in the following table:

MULTIPLIER BITS FROM STEP 1			OPERATOR SYMBOL	TO OBTAIN PARTIAL PRODUCT
$2^{2i-1}$	$2^{2i-2}$	$2^{2i-3}$		
0	0	0	0	Replace multiplicand by zero
0	0	1	+1 B	Copy multiplicand
0	1	0	+1 B	Copy multiplicand
0	1	1	+2 B	Shift multiplicand left one bit
1	0	0	-2 B	Shift two's complement of multiplicand left one bit
1	0	1	-1 B	Replace multiplicand by two's complement
1	1	0	-1 B	Replace multiplicand by two's complement
1	1	1	0	Replace multiplicand by zero

3. Weight the partial products by indexing each two places left relative to the next-less-significant product.
4. Extend the most-significant bit of the partial product to the sign-bit place value of the final product.

**EXAMPLE OF ALGORITHM**

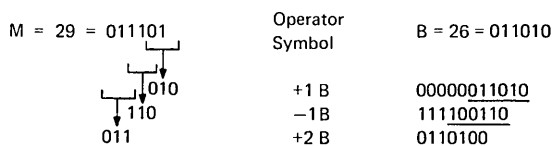

The summation of these partial products was shown in the 2-bit-at-a-time binary multiplication example above.

The 'LS261 generates partial products according to this algorithm with two exceptions:

1. The one's complement is generated for the cases requiring the two's complement. The two's complement can be obtained by adding one to the one's complement; this rounding can be done by using one NAND gate and one AND gate as shown in Figure B.
2. The most-significant bit is complemented to reduce the hardware required to extend the sign bit. This extension can be accomplished by adding a hard-wired logic 1 in bit position  $2^{2i+15}$  of each partial product and also in bit position  $2^{16}$  of the first partial product (PP1).

**2**  
TTL Devices

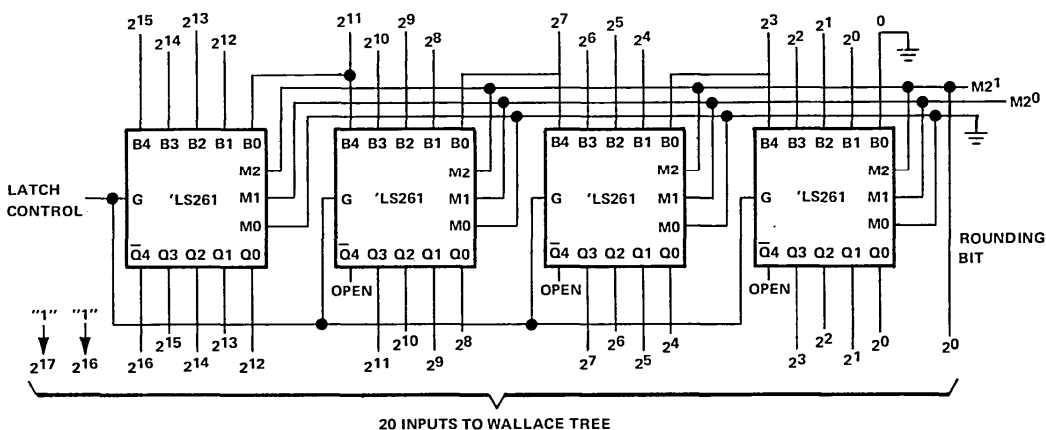

FIGURE A — FIRST PARTIAL PRODUCT, PP1

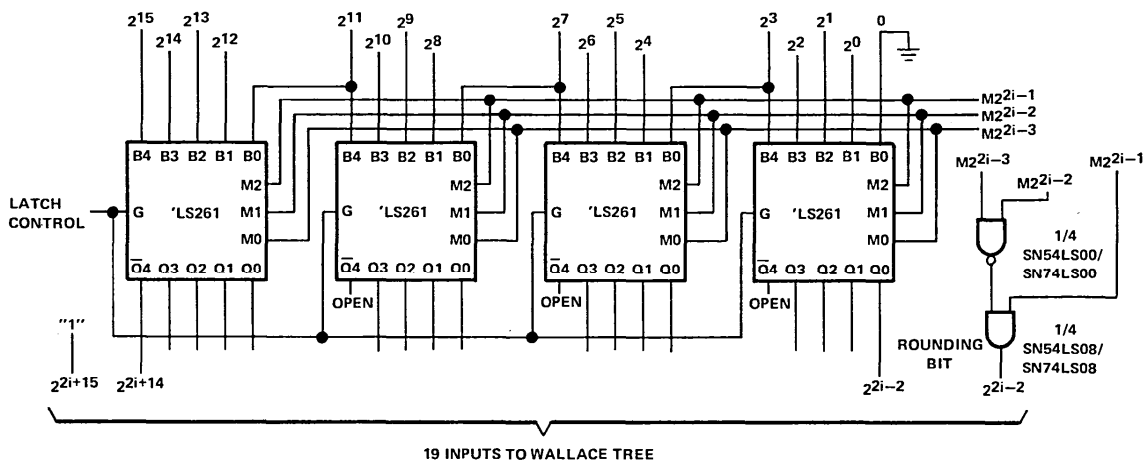

FIGURE B — OTHER PARTIAL PRODUCTS, PPI

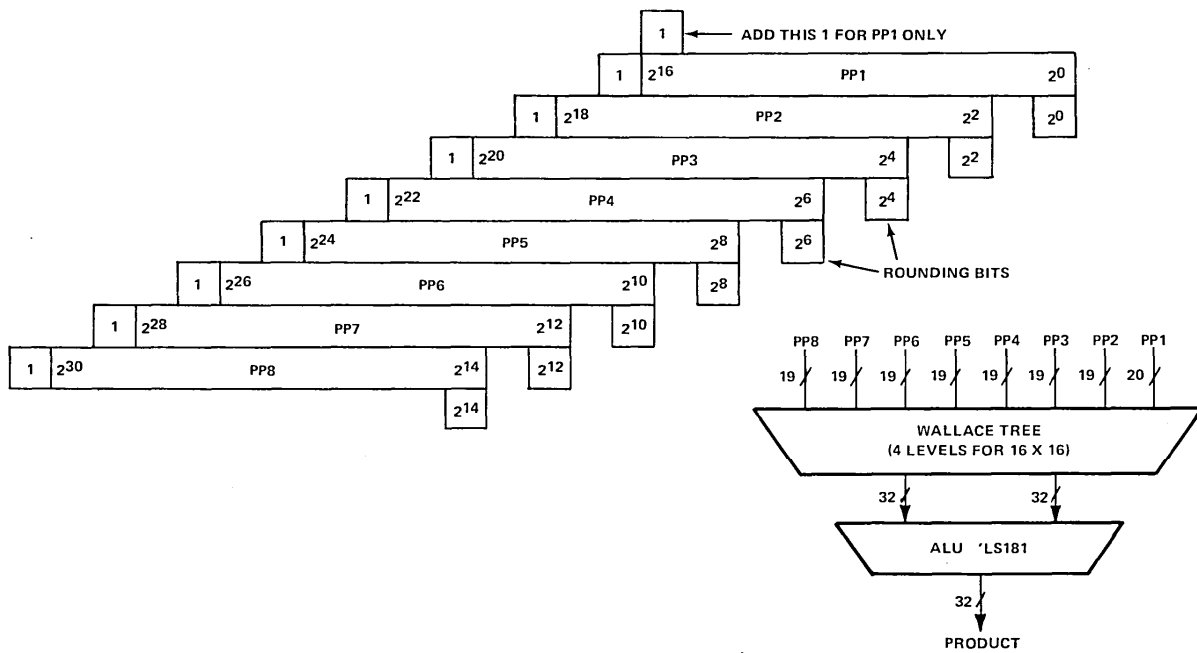

FIGURE C—MANIPULATION OF PARTIAL PRODUCTS FOR ENTRY INTO WALLACE TREE

In general, the 4 x 2 bit 'LS261 can be expanded for use in 4m x 2n bit multipliers. Partial-product generation uses m x n 'LS261s, m x n ÷ 16 'LS00s, and m x n ÷ 16 'LS08s. The size of the Wallace tree and ALU requirements vary depending on the size of the problem. The count for the 16 x 16 bit multiplier is:

32	SN54LS261/SN74LS261
2	SN54LS00/SN74LS00
2	SN54LS08/SN74LS08
56	SN54LS183/SN74LS183
7	SN54LS181/SN74LS181
2	SN54S182/SN74S182