

**TYPES SN54H78, SN54L78, SN54LS78A,  
SN74H78, SN74LS78A**  
**DUAL J-K FLIP-FLOPS WITH PRESET, COMMON CLOCK, AND COMMON CLEAR**  
REVISED DECEMBER 1983

- Package Options Include Plastic and Ceramic DIPs
- Dependable Texas Instruments Quality and Reliability

**description**

The 'H78 and 'L78 contain two J-K flip-flops with individual J-K, preset inputs, and common clock and common clear inputs. The 'H78 and 'L78 are positive pulse-triggered flip-flops. J-K input is loaded into the master while the clock is high and transferred to the slave on the high-to-low transition. For these devices the J and K inputs must be stable while the clock is high.

The 'LS78A contain two negative-edge-triggered flip-flops with individual J-K, preset inputs, and common clock and common clear inputs. The logic levels at the J and K inputs may be allowed to change while the clock pulse is high and the flip-flop will perform according to the function table as long as minimum setup and hold times are observed. The preset and clear are asynchronous active low inputs. When low they override the clock and data inputs forcing the outputs to the steady state levels as shown in the function table.

The SN54H78, SN54L78, and the SN54LS78A are characterized for operation over the full military temperature range of -55°C to 125°C. The SN74H78 and the SN74LS78A are characterized for operation from 0°C to 70°C.

FOR CHIP CARRIER INFORMATION,  
CONTACT THE FACTORY

SN54H78 ... J PACKAGE  
SN74H78 ... J OR N PACKAGE  
(TOP VIEW)

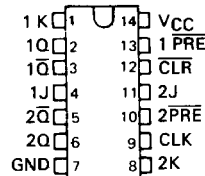

SN54L78 ... J PACKAGE  
SN54LS78A ... J OR W PACKAGE  
SN74LS78A ... D, J OR N PACKAGE  
(TOP VIEW)

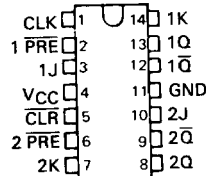

'H78, 'L78  
FUNCTION TABLE

INPUTS					OUTPUTS	
PRE	CLR	CLK	J	K	Q	Q̄
L	H	X	X	X	H	L
H	L	X	X	X	L	H
L	L	X	X	X	H†	H†
H	H	↓	L	L	Q <sub>0</sub>	Q̄ <sub>0</sub>
H	H	↓	H	L	H	L
H	H	↓	L	H	L	H
H	H	↓	H	H	TOGGLE	TOGGLE
H	H	↓	H	H	Q <sub>0</sub>	Q̄ <sub>0</sub>

'LS78A

INPUTS					OUTPUTS	
PRE	CLR	CLK	J	K	Q	Q̄
L	H	X	X	X	H	L
H	L	X	X	X	L	H
L	L	X	X	X	H†	H†
H	H	↓	L	L	Q <sub>0</sub>	Q̄ <sub>0</sub>
H	H	↓	H	L	H	L
H	H	↓	L	H	L	H
H	H	↓	H	H	TOGGLE	TOGGLE
H	H	↓	H	X	Q <sub>0</sub>	Q̄ <sub>0</sub>

† This configuration is nonstable; that is, it will not persist when preset and clear inputs return to their inactive (high) level.

**PRODUCTION DATA**  
This document contains information current as of publication date. Products conform to specifications per the terms of Texas Instruments standard warranty. Production processing does not necessarily include testing of all parameters.



POST OFFICE BOX 225012 • DALLAS, TEXAS 75265

TYPES SN54H78, SN54L78, SN74H78  
 DUAL J-K FLIP-FLOPS WITH PRESET, COMMON CLOCK, AND COMMON CLEAR

logic diagrams

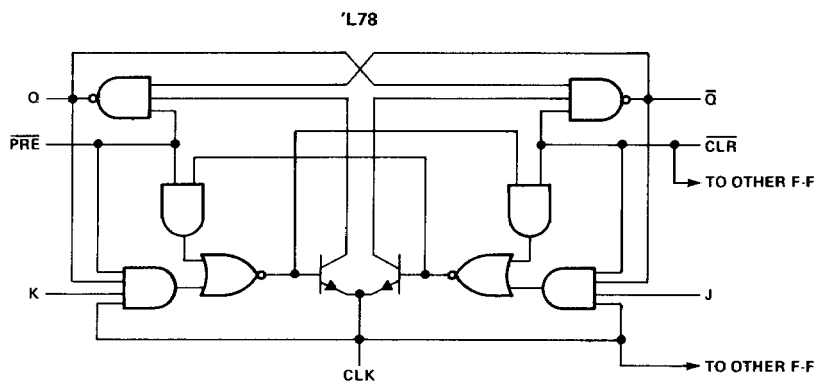
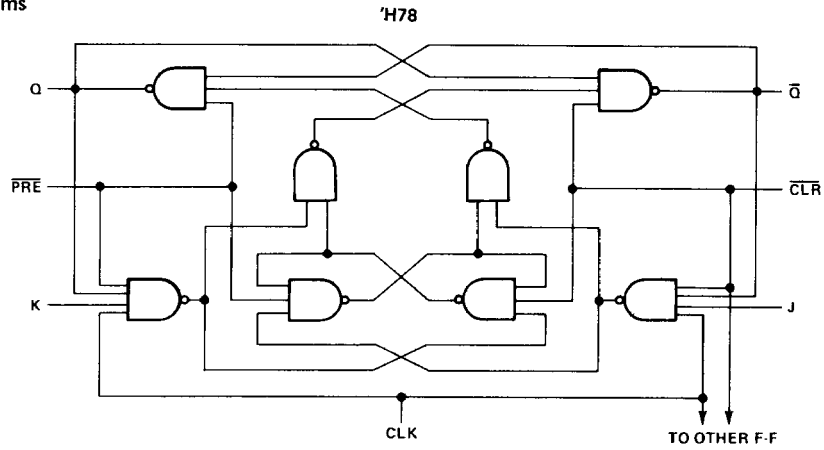

3  
 TTL DEVICES

TYPES SN54H78, SN54L78, SN54LS78A,  
SN74H78, SN74LS78A

**DUAL J-K FLIP-FLOPS WITH PRESET, COMMON CLOCK, AND COMMON CLEAR**

logic diagrams (continued)

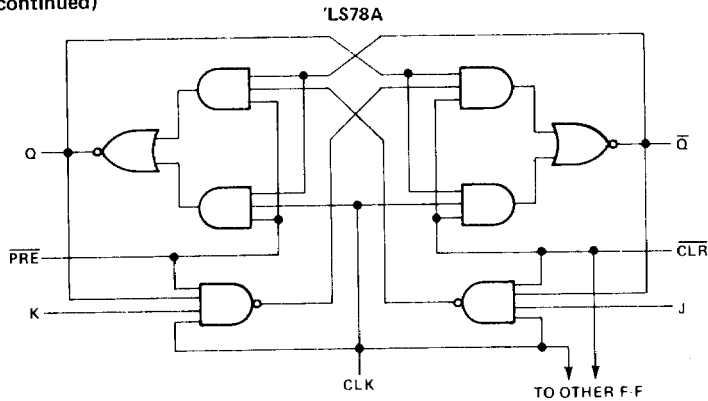

logic symbols

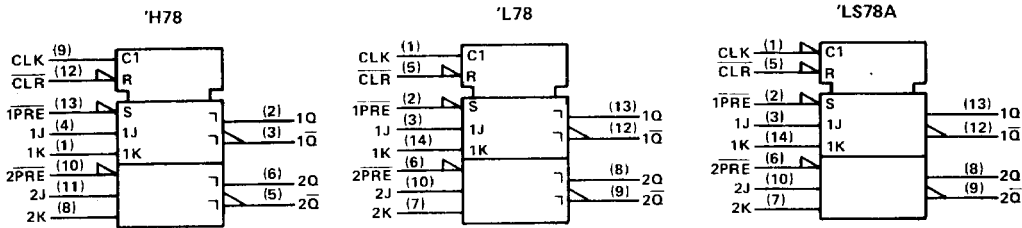

Pin numbers shown on logic notation are for D, J or N packages.

schematics of inputs and outputs

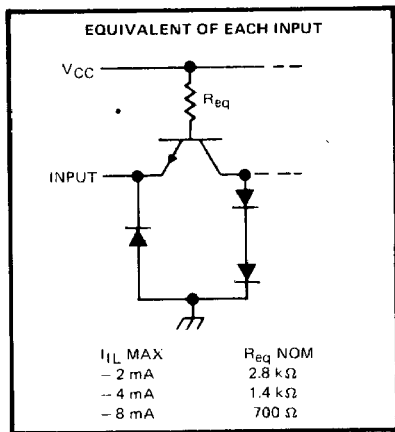

'H78

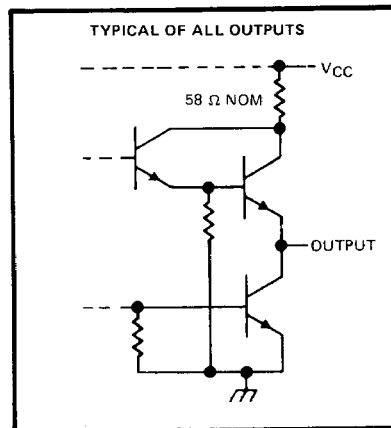

3

TTL DEVICES

**TYPE SN54H78, SN54L78, SN54LS78A,  
SN74H78, SN74LS78A  
DUAL J-K FLIP-FLOPS WITH PRESET, COMMON CLOCK, AND COMMON CLEAR**

schematics of inputs and outputs (continued)

**3** TTL DEVICES

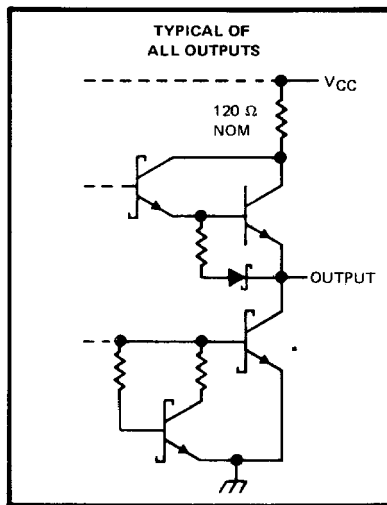
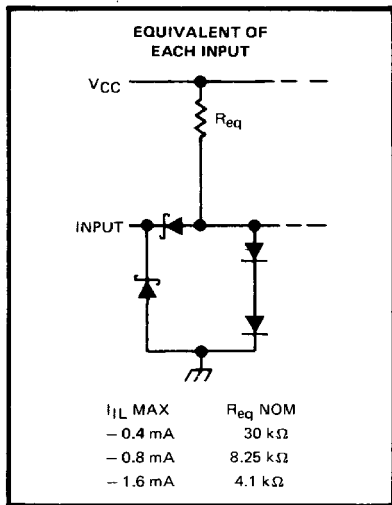
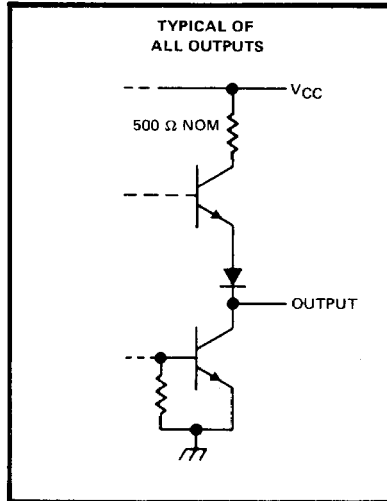
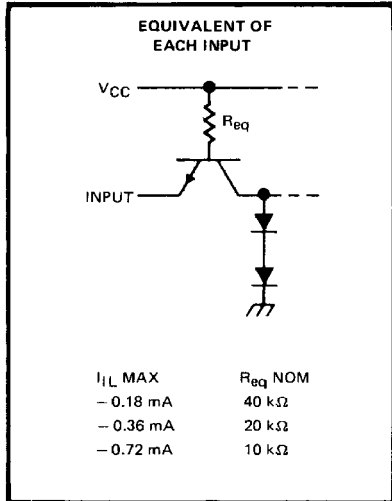

absolute maximum ratings over operating free-air temperature range (unless otherwise noted)

Supply voltage, $V_{CC}$ (see Note 1)	7 V
Input voltage: 'H78, 'L78	5.5 V
'LS78A	7 V
Operating free-air temperature range: SN54'	-55°C to 125°C
SN74'	0°C to 70°C
Storage temperature range	-65°C to 150°C

NOTE 1: Voltage values are with respect to network ground terminal.

TYPES SN54H78, SN74H78

**DUAL J-K FLIP-FLOPS WITH PRESET, COMMON CLEAR, AND COMMON CLOCK**

**recommended operating conditions**

		SN54H78			SN74H78			UNIT
		MIN	NOM	MAX	MIN	NOM	MAX	
V <sub>CC</sub>	Supply voltage	4.5	5	5.5	4.75	5	5.25	V
V <sub>IH</sub>	High-level input voltage	2			2			V
V <sub>IL</sub>	Low-level input voltage	0.8			0.8			V
I <sub>OH</sub>	High-level output current	-0.5			-0.5			mA
I <sub>OL</sub>	Low-level output current	20			20			mA
t <sub>w</sub>	Pulse duration	CLK high		12		12		ns
		CLK low		28		28		
		CLR or PRE low		16		16		
t <sub>su</sub>	Setup time before CLK ↑	data high or low		0		0		ns
t <sub>h</sub>	Hold time-data after CLK ↓	0		0		0		ns
T <sub>A</sub>	Operating free-air temperature	-55	125	0	70	°C		

**electrical characteristics over recommended operating free-air temperature range (unless otherwise noted)**

PARAMETER	TEST CONDITIONS†	SN54H78			SN74H78			UNIT
		MIN	TYP‡	MAX	MIN	TYP‡	MAX	
V <sub>IK</sub>	V <sub>CC</sub> = MIN, I <sub>I</sub> = -8 mA	-1.5			-1.5			V
V <sub>OH</sub>	V <sub>CC</sub> = MIN, V <sub>IH</sub> = 2 V, V <sub>IL</sub> = 0.8 V, I <sub>OH</sub> = -0.5 mA	2.4	3.4		2.4	3.4	V	
V <sub>OL</sub>	V <sub>CC</sub> = MIN, V <sub>IH</sub> = 2 V, V <sub>IL</sub> = 0.8 V, I <sub>OL</sub> = 20 mA	0.2	0.4		0.2	0.4	V	
I <sub>I</sub>	V <sub>CC</sub> = MAX, V <sub>I</sub> = 5.5 V	1			1			mA
I <sub>IH</sub>	J or K	50			50			μA
	CLR	200			200			
	PRE or CLK	100			100			
I <sub>IL</sub>	J or K	-2			-2			mA
	CLR*	-8			-8			
	PRE*	-4			-4			
	CLK	-4			-4			
I <sub>OS</sub> §	V <sub>CC</sub> = MAX	-40	-100		-40	-100	mA	
I <sub>CC</sub>	V <sub>CC</sub> = MAX, See Note 2	16 25			16 25			mA

† For conditions shown as MIN or MAX, use the appropriate value specified under recommended operating conditions.

‡ All typical values are at V<sub>CC</sub> = 5 V, T<sub>A</sub> = 25°C.

§ Not more than output should be shorted at a time, and the duration of the short circuit should not exceed one second.

\* Clear is tested with preset high and preset is tested with clear high.

NOTE 2: With all outputs open, I<sub>CC</sub> is measured with the Q and  $\bar{Q}$  outputs high in turn. At the time of measurement, the clock input is grounded.

**switching characteristics, V<sub>CC</sub> = 5 V, T<sub>A</sub> = 25°C (see note 3)**

PARAMETER	FROM (INPUT)	TO (OUTPUT)	TEST CONDITIONS	MIN	TYP	MAX	UNIT
f <sub>max</sub>				25	30		MHz
t <sub>PLH</sub>	CLR or PRE	Q or $\bar{Q}$	R <sub>L</sub> = 280 Ω, C <sub>L</sub> = 25 pF	6	13		ns
t <sub>PHL</sub>				12	24		ns
t <sub>PLH</sub>	CLK	Q or $\bar{Q}$		14	21		ns
t <sub>PHL</sub>				22	27		ns

NOTE 3: See General Information Section for load circuits and voltage waveforms.

**3**  
TTL DEVICES

**TYPE SN54L78**  
**DUAL J-K FLIP-FLOPS WITH PRESET, COMMON CLOCK, AND COMMON CLEAR**

**recommended operating conditions**

		MIN	NOM	MAX	UNIT
V <sub>CC</sub>	Supply voltage	4.5	5	5.5	V
V <sub>IH</sub>	High-level input voltage	2			V
V <sub>IL</sub>	Low-level input voltage	Clock input		0.6	V
		All other inputs		0.7	
I <sub>OH</sub>	High-level output current			-0.1	mA
I <sub>OL</sub>	Low-level output current			2	mA
t <sub>w</sub>	Pulse duration	CLK high or low		200	ns
		CLR or PRE low		100	
t <sub>su</sub>	Setup time before CLK †			0	ns
t <sub>h</sub>	Hold time data after CLK †			0	ns
T <sub>A</sub>	Operating free-air temperature	-55		125	°C

**electrical characteristics over recommended operating free-air temperature range (unless otherwise noted)**

PARAMETER	TEST CONDITIONS†			MIN	TYP‡	MAX	UNIT
V <sub>OH</sub>	V <sub>CC</sub> = MIN, V <sub>IH</sub> = 2 V, V <sub>IL</sub> = MAX, I <sub>OH</sub> = -0.1 mA			2.4	3.3		V
V <sub>OL</sub>	V <sub>CC</sub> = MIN, V <sub>IH</sub> = 2 V, V <sub>IL</sub> = MAX, I <sub>OL</sub> = 2 mA			0.15			V
I <sub>I</sub>	J or K	V <sub>CC</sub> = MAX, V <sub>I</sub> = 5.5 V				0.1	mA
	PRE					0.2	
	CLK or CLR					0.4	
I <sub>IH</sub>	J or K	V <sub>CC</sub> = MAX, V <sub>I</sub> = 2.4 V				10	μA
	CLR					40	
	PRE					20	
	CLK					-400	
I <sub>IL</sub>	J or K	V <sub>CC</sub> = MAX, V <sub>I</sub> = 0.3 V				-0.18	mA
	PRE					-0.36	
	CLK or CLR					-0.72	
I <sub>OS</sub>	V <sub>CC</sub> = MAX			-3		-15	mA
I <sub>CC</sub>	V <sub>CC</sub> = MAX, See Note 2			0.76		1.44	mA

† For conditions shown as MIN or MAX, use the appropriate value specified under recommended operating conditions.

‡ All typical values are at V<sub>CC</sub> = 5 V, T<sub>A</sub> = 25°C.

NOTE 2: With all outputs open, I<sub>CC</sub> is measured with the Q and  $\bar{Q}$  outputs high in turn. At the time of measurement the clock input is grounded.

**switching characteristics, V<sub>CC</sub> = 5 V, T<sub>A</sub> = 25°C (see note 3)**

PARAMETER	FROM (INPUT)	TO (OUTPUT)	TEST CONDITIONS	MIN	TYP	MAX	UNIT
f <sub>max</sub>			R <sub>L</sub> = 4 kΩ, C <sub>L</sub> = 50 pF	2.5	3		MHz
t <sub>PLH</sub>	PRE or CLR	Q or $\bar{Q}$		35	75		ns
t <sub>PHL</sub>	PRE or CLR (CLK high)	$\bar{Q}$ or O		60	150		ns
	PRE or CLR (CLK low)			200			
t <sub>PLH</sub>	CLK	Q or $\bar{Q}$		10	35	75	ns
t <sub>PHL</sub>				10	60	150	

NOTE 3: See General Information Section for load circuits and voltage waveforms.

**3**  
TTL DEVICES

**TYPES SN54LS78A, SN74LS78A**  
**DUAL J-K FLIP-FLOPS WITH PRESET, COMMON CLOCK, AND COMMON CLEAR**

**recommended operating conditions**

		SN54LS78A			SN74LS78A			UNIT		
		MIN	NOM	MAX	MIN	NOM	MAX			
V <sub>CC</sub>	Supply voltage	4.5	5	5.5	4.75	5	5.75	V		
V <sub>IH</sub>	High-level input voltage	2			2			V		
V <sub>IL</sub>	Low-level input voltage			0.7			0.8	V		
I <sub>OH</sub>	High-level output current			-0.4			-0.4	mA		
I <sub>OL</sub>	Low-level output current			4			8	mA		
f <sub>clock</sub>	Clock frequency	0		30	0		30	MHz		
t <sub>w</sub>	Pulse duration	CLK high		20	20			ns		
		PRE or CLR low		25	25					
t <sub>su</sub>	Setup time before CLK ↓	data high or low		20	20			ns		
		PRE or CLR inactive		20	20					
t <sub>h</sub>	Hold time-data after CLK ↓	0			0			ns		
T <sub>A</sub>	Operating free-air temperature	-65			125			0	70	°C

**electrical characteristics over recommended operating free-air temperature range (unless otherwise noted)**

PARAMETER	TEST CONDITIONS†	SN54LS78A			SN74LS78A			UNIT
		MIN	TYP‡	MAX	MIN	TYP‡	MAX	
V <sub>IK</sub>	V <sub>CC</sub> = MIN, I <sub>I</sub> = -18 mA			-1.5			-1.5	V
V <sub>OH</sub>	V <sub>CC</sub> = MIN, V <sub>IH</sub> = 2 V, V <sub>IL</sub> = 0.7 V, I <sub>OH</sub> = -0.4 mA	2.5	3.4					V
	V <sub>CC</sub> = MIN, V <sub>IH</sub> = 2 V, V <sub>IL</sub> = 0.8 V, I <sub>OH</sub> = -0.4 mA				2.7	3.4		V
V <sub>OL</sub>	V <sub>CC</sub> = MIN, V <sub>IL</sub> = MAX, V <sub>IH</sub> = 2 V, I <sub>OL</sub> = 4 mA		0.25	0.4		0.25	0.4	V
	V <sub>CC</sub> = MIN, V <sub>IL</sub> = MAX, V <sub>IH</sub> = 2 V, I <sub>OL</sub> = 8 mA					0.35	0.5	V
I <sub>I</sub>	V <sub>CC</sub> = MAX, V <sub>I</sub> = 7 V	J or K		0.1			0.1	mA
		CLR		0.6			0.6	
		PRE		0.3			0.3	
		CLK		0.8			0.8	
I <sub>IH</sub>	V <sub>CC</sub> = MAX, V <sub>I</sub> = 2.7 V	J or K		20			20	μA
		CLR		120			120	
		PRE		60			60	
		CLK		160			160	
I <sub>IL</sub>	V <sub>CC</sub> = MAX, V <sub>I</sub> = 0.4 V	J or K		-0.4			-0.4	mA
		CLR		-1.6			-1.6	
		PRE		-0.8			-0.8	
		CLK		-1.6			-1.6	
I <sub>OS</sub> §	V <sub>CC</sub> = MAX, See Note 4	-20		-100	-20		-100	mA
I <sub>CC</sub>	V <sub>CC</sub> = MAX, See Note 2		4	6		4	6	mA

† For conditions shown as MIN or MAX, use the appropriate value specified under recommended operating conditions.

‡ All typical values are at V<sub>CC</sub> = 5 V, T<sub>A</sub> = 25°C.

§ Not more than one output should be shorted at a time, and the duration of the short circuit should not exceed one second.

NOTE 2: With all outputs open, I<sub>CC</sub> is measured with the Q and Q outputs high in turn. At the time of measurement, the clock input is grounded.

NOTE 4: For certain devices where state commutation can be caused by shorting an output to ground, an equivalent test may be performed with V<sub>O</sub> = 2.25 V and 2.125 V for the 54 family and the 74 family, respectively, with the minimum and maximum limits reduced to one half of their stated values.

**3**  
TTL DEVICES

**TYPES SN54LS78A, SN74LS78A**  
**DUAL J-K FLIP-FLOPS WITH PRESET, COMMON CLOCK, AND COMMON CLEAR**

switching characteristics,  $V_{CC} = 5\text{ V}$ ,  $T_A = 25^\circ\text{C}$  (see note 3)

PARAMETER	FROM (INPUT)	TO (OUTPUT)	TEST CONDITIONS	MIN	TYP	MAX	UNIT
$f_{max}$				30	45		MHz
$t_{PLH}$	PRE, CLR or CLK	Q or $\bar{Q}$	$R_L = 2\text{ k}\Omega$ , $C_L = 15\text{ pF}$		15	20	ns
$t_{PHL}$					15	20	ns

NOTE 3: See General Information Section for load circuits and voltage waveforms.

3

TTL DEVICES