

SILICON RECTIFIER DIODES

Also available to BS9331-F128

Diffused silicon rectifier diodes in DO-4 metal envelopes, intended for power rectifier applications.

The series consists of the following types:

Normal polarity (cathode to stud): BYX42-300 to 1200.

Reserve polarity (anode to stud): BYX42-300R to 1200R.

QUICK REFERENCE DATA

		BYX42-300(R)	600(R)	1200(R)
Repetitive peak reverse voltage	V_{RRM}	max. 300	600	1200 V
Average forward current	$I_F(AV)$	max.	12	A
Non-repetitive peak forward current	I_{FSM}	max.	125	A

MECHANICAL DATA

Dimensions in mm

DO-4

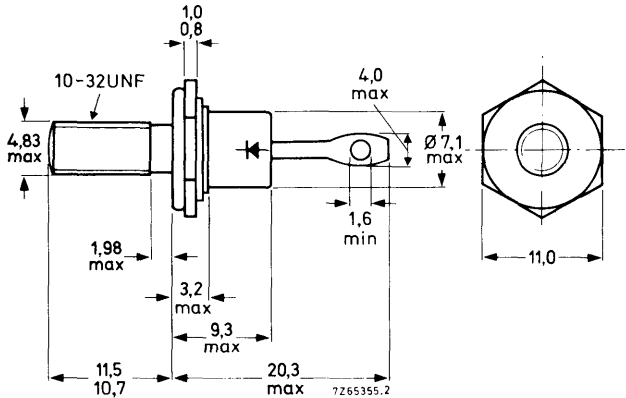

Net mass: 6 g

Diameter of clearance hole: 5,2 mm

Accessories supplied on request:

56295 (PTFE bush, 2 mica washers, plain washer, tag)

56262A (mica washer, insulating ring, plain washer)

Supplied with device: 1 nut, 1 lock washer

Nut dimensions across the flats: 9,5 mm

The mark shown applies to normal polarity types.

Torque on nut: min. 0,9 Nm

(9 kg cm)

max. 1,7 Nm

(17 kg cm)

RATINGS Limiting values in accordance with the Absolute Maximum System (IEC 134)

<u>Voltages</u>		BYX42-300(R)	600(R)	1200(R)	
Non-repetitive peak reverse voltage ($t \leq 10$ ms)	V_{RSM}	max. 300	600	1200	V
Repetitive peak reverse voltage ($\delta \leq 0,01$)	V_{RRM}	max. 300	600	1200	V
Crest working reverse voltage	V_{RWM}	max. 200	400	800	V
Continuous reverse voltage	V_R	max. 200	400	800	V

Currents

Average forward current (averaged over any 20 ms period) up to $T_{mb} = 115$ °C at $T_{mb} = 125$ °C	$I_{F(AV)}$	max.	12	A
	$I_{F(AV)}$	max.	10	A
R. M. S. forward current	$I_{F(RMS)}$	max.	20	A
Repetitive peak forward current	I_{FRM}	max.	60	A
Non-repetitive peak forward current ($t = 10$ ms; half sine-wave) $T_j = 175$ °C prior to surge; with reapplied V_{RWMmax}	I_{FSM}	max.	125	A

Temperatures

Storage temperature	T_{stg}	-55 to +175	°C
Junction temperature	T_j	max. 175	°C

THERMAL RESISTANCE

From junction to ambient in free air	$R_{th j-a}$	=	50	°C/W
From junction to mounting base	$R_{th j-mb}$	=	3	°C/W
From mounting base to heatsink	$R_{th mb-h}$	=	0,5	°C/W

CHARACTERISTICS

<u>Forward voltage</u> at $I_F = 15$ A; $T_j = 25$ °C	V_F	<	1,4	V ¹⁾
<u>Reverse current</u> † at $V_R = V_{RWMmax}$; $T_j = 125$ °C	I_R	<	200	µA

MOUNTING INSTRUCTIONS

The top connector should neither be bent nor twisted; it should be soldered into the circuit so that there is no strain on it.

During soldering the heat conduction to the junction should be kept to a minimum.

¹⁾ Measured under pulse conditions to avoid excessive dissipation.

7272553

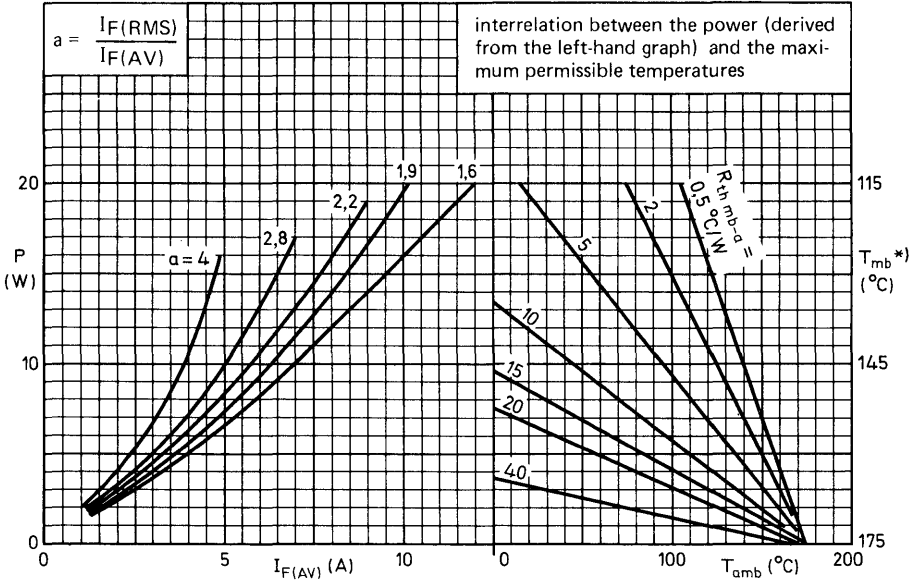

*) T_{mb} -scale is for comparison purposes only and is correct only for $R_{\text{th mb-a}} \leq 22 \text{ } ^{\circ}\text{C/W}$

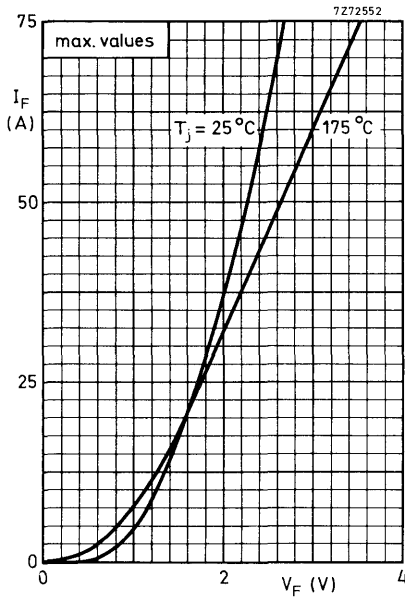

**BYX42
SERIES**

7272554

