

Aluminum Electrolytic Capacitors

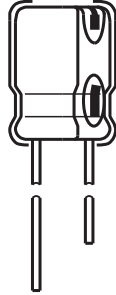

FEATURES

- Polarized aluminum electrolytic capacitors, non-solid electrolyte
- Radial leads, cylindrical aluminum case
- Pressure relief for case $\varnothing D \geq 6.3$ mm
- High CV per unit volume
- $\varnothing 5$ mm to $\varnothing 25$ mm, 105 °C, 2000 h endurance
- Material categorization: for definitions of compliance please see www.vishay.com/doc?99912

RoHS
COMPLIANT

APPLICATIONS

- Decoupling, smoothing, filtering, buffering in SMPS
- General industrial, telecom, and domestic appliances
- Portable and mobile equipment (small size, low mass)

QUICK REFERENCE DATA		
DESCRIPTION	UNIT	VALUE
Nominal case sizes ($\varnothing D \times L$)	mm	5 x 11 to 25 x 45
Rated capacitance range	μF	1 to 33 000
Capacitance tolerance	%	± 20 (at 120 Hz, 20 °C)
Rated voltage range	V _{DC}	6.3 to 450
Category temperature range	°C	-40 to +105
Endurance	h	2000
Shelf life	h	1000

ORDERING INFORMATION						
Part number example: GRC00FE1021VTFL						
GRC	00	FE	102	1V	TF	L
SERIES NAME	DESIGN / FORMING	DIMENSIONS	CAPACITANCE	VOLTAGE	PACKING	INTERNAL CODE
		See "Dimensions" table	See "Selection Chart"	See "Selection Chart"	00 = bulk TF = ammopack, formed lead ⁽¹⁾ TN = ammopack, straight lead ⁽¹⁾	

Note
⁽¹⁾ See "Taping Specifications"

**ADDITIONAL ELECTRICAL DATA**

LEAKAGE CURRENT (Test conditions: U_R , 20 °C)			
RATED VOLTAGE	TIME	CV	VALUE
6.3 V to 100 V	after 2 min		$I = 0.01 CV$ or 3 (μA), whichever is greater
160 V to 450 V	after 5 min	$CV \leq 1000$	$I = 0.03 CV + 15$ (μA)
		$CV > 1000$	$I = 0.02 CV + 25$ (μA)

Notes

- Where, C = rated capacitance in μF
- V = rated DC working voltage in V

DISSIPATION FACTOR ($\tan \delta$ at 120 Hz, 20 °C)														
RATED VOLTAGE	6.3	10	16	25	35	50	63	100	160	200	250	350	400	450
$\tan \delta$ (max.)	0.23	0.20	0.16	0.14	0.12	0.10	0.09	0.08	0.12	0.14	0.17	0.20	0.25	0.25

Note

- When the capacitance exceeds 1000 μF , 0.02 shall be added every 1000 μF increase.

LOW TEMPERATURE BEHAVIOR (at 120 Hz)															
IMPEDANCE RATIO	CASE SIZE	RATED VOLTAGE													
		6.3	10	16	25	35	50	63	100	160	200	250	350	400	450
$\frac{Z_{(-25\text{ °C})}}{Z_{(+20\text{ °C})}}$	$\emptyset D < 16$	4	3	3	2	2	2	2	2	3	6	8	12	14	16
	$\emptyset D \geq 16$	6	4	4	3	3	3	3	3						
$\frac{Z_{(-40\text{ °C})}}{Z_{(+20\text{ °C})}}$	$\emptyset D < 16$	8	6	6	4	4	3	3	3	4	8	10	16	18	20
	$\emptyset D \geq 16$	12	10	8	8	8	8	6	6						

MULTIPLIER OF RIPPLE CURRENT AS A FUNCTION OF FREQUENCY			
FREQUENCY (Hz)	CAPACITANCE (μF)		
	< 100	100 < C ≤ 1000	1000 AND UP
60 (50)	0.70	0.75	0.80
120	1.00	1.00	1.00
500	1.30	1.20	1.10
1000	1.40	1.30	1.12
10 000 and up	1.50	1.35	1.15

TEST PROCEDURES AND REQUIREMENTS				
TEST	TEST TIME	CAPACITANCE CHANGE	DISSIPATION FACTOR	LEAKAGE CURRENT
Load life ⁽¹⁾	2000 h	Within ± 20 % of initial value	Less than 200 % of specified value	Within specified value
Shelf life ⁽²⁾	1000 h			

Notes

- (1) The specifications shall be satisfied when the capacitors are restored to 20 °C after the rated voltage applied with rated ripple current for 2000 h at 105 °C.
- (2) The above specifications shall be satisfied when the capacitors are restored to 20 °C after exposing them for 1000 h at 105 °C without voltage applied. The rated voltage shall be applied to the capacitors before the measurements for 160 V to 450 V (refer to JIS C 5101-4 4.1).

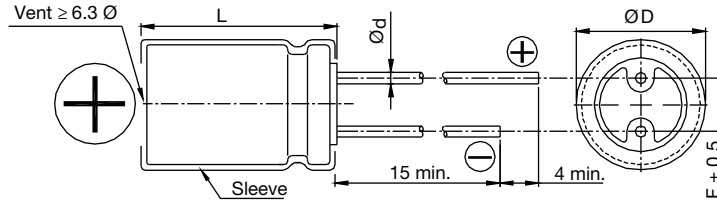
DIMENSIONS in millimeters

CASE SIZE CODE		$\text{Ø D} + 0.5$	L	Ø d	$F \pm 0.5$
AA	5 x 11	5	11 ± 1.0	0.5	2
BA	6.3 x 11	6.3	11 ± 1.0	0.5	2.5
PB	8 x 11.5	8	11.5 ± 1.0	0.6	3.5
DC	10 x 12.5	10	12.5 ± 1.5	0.6	5
DD	10 x 16	10	16 ± 1.5	0.6	5
DE	10 x 20	10	20 ± 2.0	0.6	5
DG	10 x 25	10	25 ± 2.0	0.6	5
FD	12.5 x 16	12.5	16 ± 1.5	0.6	5
FE	12.5 x 20	12.5	20 ± 2.0	0.6	5
FG	12.5 x 25	12.5	25 ± 2.0	0.6	5
JD	16 x 16	16	16 ± 1.5	0.8	7.5
JE	16 x 20	16	20 ± 2.0	0.8	7.5
JG	16 x 25	16	25 ± 2.0	0.8	7.5
JS	16 x 31.5	16	31.5 ± 2.0	0.8	7.5
JL	16 x 35.5	16	35.5 ± 2.0	0.8	7.5
JK	16 x 40	16	40 ± 2.0	0.8	7.5
KD	18 x 16	18	16 ± 1.5	0.8	7.5
KE	18 x 20	18	20 ± 2.0	0.8	7.5
KG	18 x 25	18	25 ± 2.0	0.8	7.5
KS	18 x 31.5	18	31.5 ± 2.0	0.8	7.5
KL	18 x 35.5	18	35.5 ± 2.0	0.8	7.5
KK	18 x 40	18	40 ± 2.0	0.8	7.5
KW	18 x 45	18	45 ± 2.0	0.8	7.5
LK	22 x 40	22	40 ± 2.0	1.0	10
PK	25 x 40	25	40 ± 2.0	1.0	12.5
PW	25 x 45	25	45 ± 2.0	1.0	12.5

Note

- Please see "Taping Specifications" for details on taped products



SELECTION CHART, DIMENSIONS, AND PERMISSIBLE RIPPLE CURRENT (at 120 Hz / 105 °C)															
V_{DC}		6.3 V (0J)		10 V (1A)		16 V (1C)		25 V (1E)		35 V (1V)		50 V (1H)		63 V (1J)	
CAP.	CODE	Ø D x L	mA	Ø D x L	mA	Ø D x L	mA	Ø D x L	mA	Ø D x L	mA	Ø D x L	mA	Ø D x L	mA
2.2	2R2											5 x 11	20		
3.3	3R3											5 x 11	30		
4.7	4R7											5 x 11	33		
10	100											5 x 11	50		
22	220											5 x 11	78	6.3 x 11	86
33	330									5 x 11	75	5 x 11	90	6.3 x 11	100
47	470							5 x 11	97	5 x 11	90	6.3 x 11	120	6.3 x 11 8 x 11.5	130 141
100	101					5 x 11	110	6.3 x 11	142	6.3 x 11	150	8 x 11.5	188	10 x 12.5	235
220	221	5 x 11	140	6.3 x 11	175	6.3 x 11	190	8 x 11.5	236	8 x 11.5	270	10 x 12.5	300	10 x 16	335
330	331			6.3 x 11	200	8 x 11.5	270	8 x 11.5 10 x 12.5	310 335	10 x 12.5	350	10 x 16	410	10 x 20 12.5 x 16	510 460
470	471	6.3 x 11	230	8 x 11.5	290	8 x 11.5	310	10 x 12.5	380	10 x 16	460	10 x 20 12.5 x 16	530 425	12.5 x 20 16 x 16	640 665
1000	102	8 x 11.5	380	10 x 12.5	460	10 x 16	560	10 x 20 12.5 x 16	680 590	12.5 x 20 16 x 16	810 720	12.5 x 25 16 x 20	950 830	16 x 25	930
2200	222	10 x 16	690	10 x 20	760	12.5 x 16	780	12.5 x 25	1110	16 x 25 18 x 20	1260 1110	16 x 35.5 18 x 31.5	1470 1520	18 x 40	2280
3300	332	10 x 20 12.5 x 16	840 850	12.5 x 20 16 x 16	1100 940	12.5 x 25 16 x 16	1170 950	16 x 25 18 x 20	1440 1220	16 x 31.5 18 x 25	1420 1570	18 x 35.5	1770	22 x 40	2510
4700	472	12.5 x 20 16 x 16	1090 1010	12.5 x 25 16 x 16	1260 1060	16 x 20 18 x 16	1185 1290	16 x 31.5 18 x 25	1650 1550	18 x 35.5	1900	22 x 40	2340	25 x 40	3000
6800	682	12.5 x 25 16 x 20	1460 1190	16 x 20	1270	16 x 31.5 18 x 20	1930 1585	16 x 40 18 x 35.5	2000 2160	18 x 40	2250	25 x 40	2530		
10 000	103	16 x 20	1340	16 x 31.5 18 x 25	2220 1800	16 x 35.5 18 x 31.5	2210 2330	22 x 40 18 x 45	2720 2410						
15 000	153	16 x 31.5 18 x 25	2365 2290	18 x 31.5 16 x 35.5	2620 2590	18 x 40	2950	25 x 40	3200						
22 000	223	16 x 40 18 x 35.5	2800 2930	18 x 40	3230	22 x 40	3460								
33 000	333	18 x 45	3080	22 x 40	4090	25 x 45	4500								



SELECTION CHART, DIMENSIONS, AND PERMISSIBLE RIPPLE CURRENT (at 120 Hz / 105 °C)															
V _{DC}		100 V (2A)		160 V (2C)		200 V (2D)		250 V (2E)		350 V (2V)		400 V (2G)		450 V (2W)	
CAP.	CODE	Ø D x L	mA	Ø D x L	mA	Ø D x L	mA	Ø D x L	mA	Ø D x L	mA	Ø D x L	mA	Ø D x L	mA
1.0	010											6.3 x 11	21	8 x 11.5	27
2.2	2R2	5 x 11	30			6.3 x 11	30	6.3 x 11	35	6.3 x 11	35	8 x 11.5	39	8 x 11.5	39
3.3	3R3	5 x 11	31			6.3 x 11	39	6.3 x 11	40	8 x 11.5	43	8 x 11.5	45	8 x 11.5	45
4.7	4R7	5 x 11	36			6.3 x 11	43	8 x 11.5	45	8 x 11.5 10 x 12.5	45 55	8 x 11.5 10 x 12.5	50 55	8 x 11.5 10 x 12.5	50 55
10	100	6.3 x 11	54	8 x 11.5	65	8 x 11.5	65	10 x 12.5	92	10 x 16	95	10 x 16	95	10 x 20	105
22	220	6.3 x 11 8 x 11.5	93 99	10 x 12.5	110	10 x 16	140	10 x 16	140	12.5 x 20	220	12.5 x 20	160	12.5 x 20	160
33	330	8 x 11.5	130	10 x 16	150	10 x 20	170	12.5 x 16	175	12.5 x 25 16 x 16	215 205	16 x 20	225	16 x 20 18 x 16	225 220
47	470	10 x 12.5	165	10 x 20	195	12.5 x 16	215	12.5 x 20 16 x 16	230 245	16 x 20	255	16 x 25	295	16 x 25 18 x 20	280 285
68	680			12.5 x 20	275	12.5 x 20 16 x 16	265 290	16 x 20	320	18 x 25 16 x 31.5	360 370	18 x 25 16 x 31.5	360 375	16 x 35.5 18 x 31.5	400 420
100	101	10 x 20 12.5 x 16	265 290	12.5 x 25	355	16 x 20 18 x 16	365 360	16 x 25 18 x 20	425 415	18 x 31.5 16 x 35.5	460 430	18 x 35.5	540	18 x 40	560
150	151			16 x 25	470	18 x 20	510	16 x 31.5 18 x 25	550 535	18 x 40	600	22 x 40	730	22 x 40	770
220	221	12.5 x 25 16 x 16	440 420	16 x 31.5	660	18 x 31.5	750	18 x 35.5	760	25 x 40 22 x 45	865 850	22 x 45	930		
330	331	16 x 25	620	18 x 35.5	820	18 x 40	965	22 x 40	1140	25 x 45	1070				
470	330	16 x 31.5 18 x 25	715 745	22 x 40	1130	22 x 40	1130	25 x 40	1325						
1000	102	18 x 40	1275												
2200	222	25 x 45	2400												

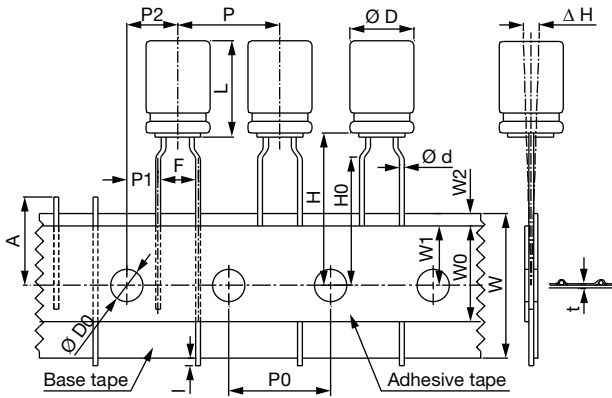

Fig. 1

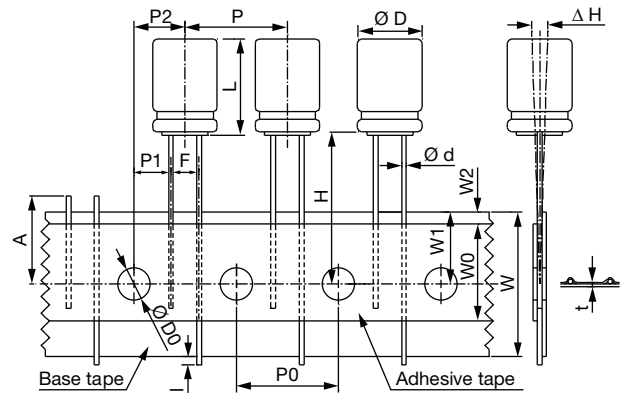

Fig. 3

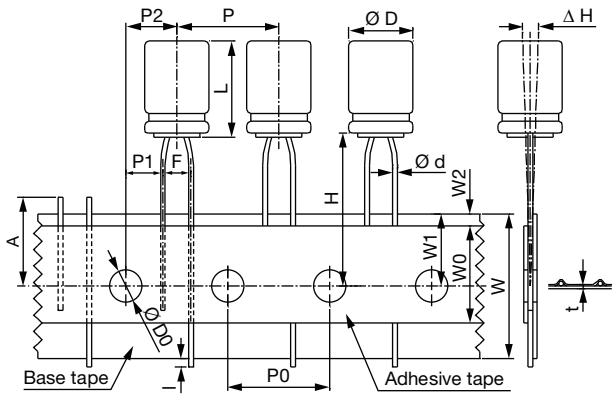

Fig. 2

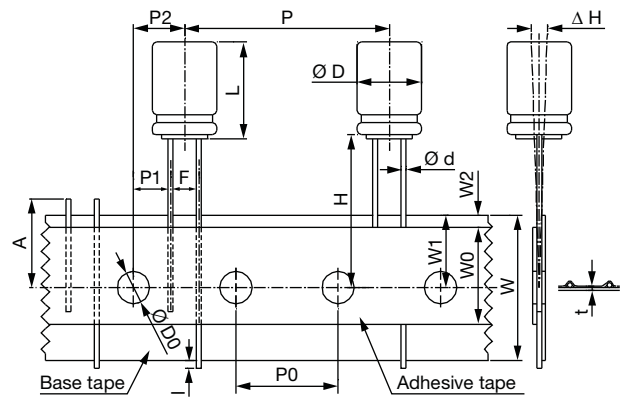

Fig. 4

TAPE SPECIFICATIONS in millimeters																										
PACKING	TF						TN																			
	5			7 to 9			≥ 11			5		≥ 7		7 to 9		11.5 to 20		9 to 25								
Ø D	3	4*	5	6.3	8	5	6.3	8*	5	6.3	8	3	4*	5	6.3	8	5	6.3	8	8	TOL.	10	12.5	TOL.		
SYMBOL																										
Ø d	0.4	0.45		0.5			0.5	0.6	0.4	0.45		0.5		0.5	0.5	0.6	± 0.05		0.6		± 0.05					
F	5.0		5.0			5.0			2.5		2.5		3.5	3.5	+ 0.8 / - 0.2		5.0		+ 0.8 / - 0.2							
H	17.5		17.5			18.5			20.0		17.5		17.5		17.5		18.5		± 0.75		18.5			± 0.75		
H0	16.0		16.0			16.0			-		-		-		-		± 0.5		-		± 0.5					
P	12.7		12.7			12.7			12.7		12.7		12.7		12.7		12.7		± 1.0		12.7		25.4		± 1.0	
P0	12.7		12.7			12.7			12.7		12.7		12.7		12.7		12.7		± 0.2		12.7			± 0.2		
P1	3.85		3.85			3.85			5.1		5.1		4.6		4.6		± 0.5		3.85		± 0.7					
P2	6.35		6.35			6.35			6.35		6.35		6.35		6.35		± 1.0		6.35		± 1.3					
W	18.0		18.0			18.0			18.0		18.0		18.0		18.0		± 0.5		18.0		± 0.5					
W0	6.0		10.0			10.0		12		6.0		10.0		10.0		12.0		Min.		12.0		Min.				
W1	9.0		9.0			9.0			9.0		9.0		9.0		9.0		± 0.5		9.0		± 0.5					
W2	1.5		1.5			1.5			1.5		1.5		1.5		1.5		Max.		1.5		Max.					
A	11.0		11.0			11.0			11.0		11.0		11.0		11.0		Max.		11.0		Max.					
Ø D0	4.0		4.0			4.0			4.0		4.0		4.0		4.0		± 0.2		4.0		± 0.2					
Δ H	0		0			0			0		0		0		0		± 1.0		0		± 1.0					
l	1.0		1.0			1.0			1.0		1.0		1.0		1.0		Max.		1.0		Max.					
t	0.7		0.7			0.7			0.7		0.7		0.7		0.7		± 0.2		0.7		± 0.2					
Fig. No.	1						2		3		2		3		3		3		3		3		4			

Notes

- For Ø D = 10, H = 20.0 ± 0.5 is available, in this case, the dimensions of H is not specified
- 4 Ø in mark of "*" is 4 Ø x 7 L the same spec. "TN" packing: 5 to 6.3 Ø x 11 L in H is 18.5
- For 3 to 8 Ø x 5 L, W0 = 10.0 is available

PACKAGING

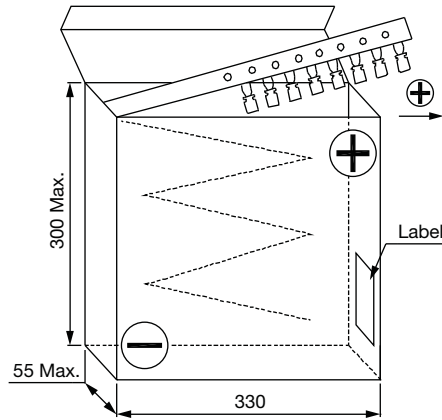

Fig. 5 - Ammopack box

PACKAGING QUANTITY (pcs per box)							
Ø D (mm)	3	4	5	6.3	8	10	12.5
TF, TN	3000	2000	2000	2000	1000	500	300

Note

- The component shall be oriented on the tape as such that the positive lead is leading or the negative lead is leading with customer's request