

92X92X25 mm

JF0925-00 Series



- **Frame** : Plastic Material UL 94V-0
- **Impeller** : Plastic Material UL 94V-0
- **Speed Range** : $\pm 10\%$

SPECIFICATIONS											
Model	Bearing	Rated Voltage (V)	Operating Voltage (V)	Air Flow (CFM)	Static Pressure (inchH ₂ O)	Speed (R.P.M.)	Input Current (Amp)	Input Power (Watt)	Nominal Current (Amp)	Noise (dBA)	Weight (g)
JF0925-1UR00	B, H	12	10.2 ~ 13.8	67.65	0.204	3500	0.35	4.20	0.42	41.9	85
JF0925-1SR00	B, H, S			60.75	0.172	3200	0.31	3.72	0.32	38.9	
JF0925-1H-00	B, H, S			52.04	0.139	2800	0.25	3.00	0.35	35.1	
JF0925-1M-00	B, H, S			46.31	0.115	2500	0.17	2.04	0.20	32.0	
JF0925-1L-00	B, H, S			38.64	0.080	2100	0.13	1.56	0.16	27.6	
JF0925-1E-00	B, H, S			30.86	0.054	1700	0.09	1.08	0.10	23.1	
JF0925-2UR00	B, H	24	20.4 ~ 27.6	67.65	0.204	3500	0.23	4.20	0.24	41.9	
JF0925-2SR00	B, H, S			60.75	0.172	3200	0.18	4.32	0.18	38.9	
JF0925-2H-00	B, H, S			52.04	0.139	2800	0.15	3.60	0.19	35.1	
JF0925-2M-00	B, H, S			46.31	0.115	2500	0.11	2.64	0.15	32.0	
JF0925-2L-00	B, H, S			38.64	0.080	2100	0.08	1.92	0.13	27.6	
JF0925-2E-00	B, H, S			30.86	0.054	1700	0.06	1.44	0.07	23.1	
JF0925B4HR00	Dual Ball	48	40.8 ~ 60.0	52.04	0.139	2800	0.09	4.32	0.09	35.1	
JF0925B4MR00				46.31	0.115	2500	0.08	3.84	0.08	32.0	
JF0925B4LR00				38.64	0.080	2100	0.06	2.88	0.06	27.6	
JF0925B4ER00				30.86	0.054	1700	0.05	2.40	0.05	23.1	

Specifications subject to change without notice

The 7TH character of Model No means the bearing code. Please refer to the page "PART NUMBER SYSTEM". Please contact us for detail if your request bearing system is not shown in the above list.

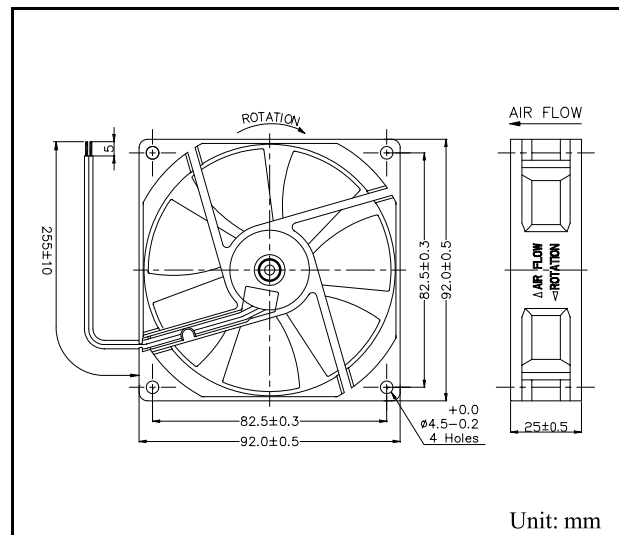
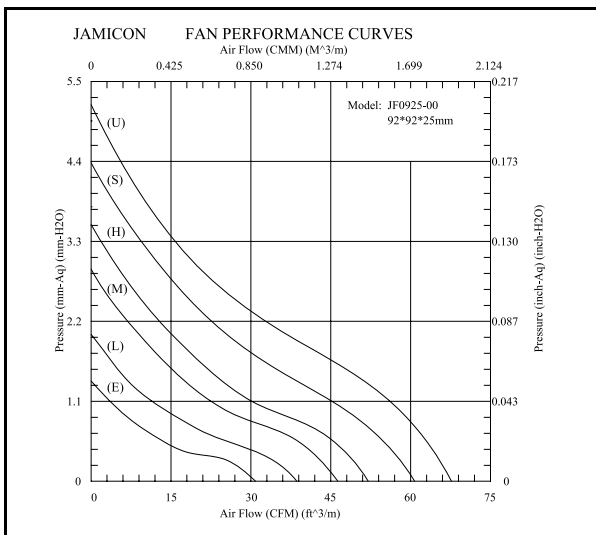

Part Number System

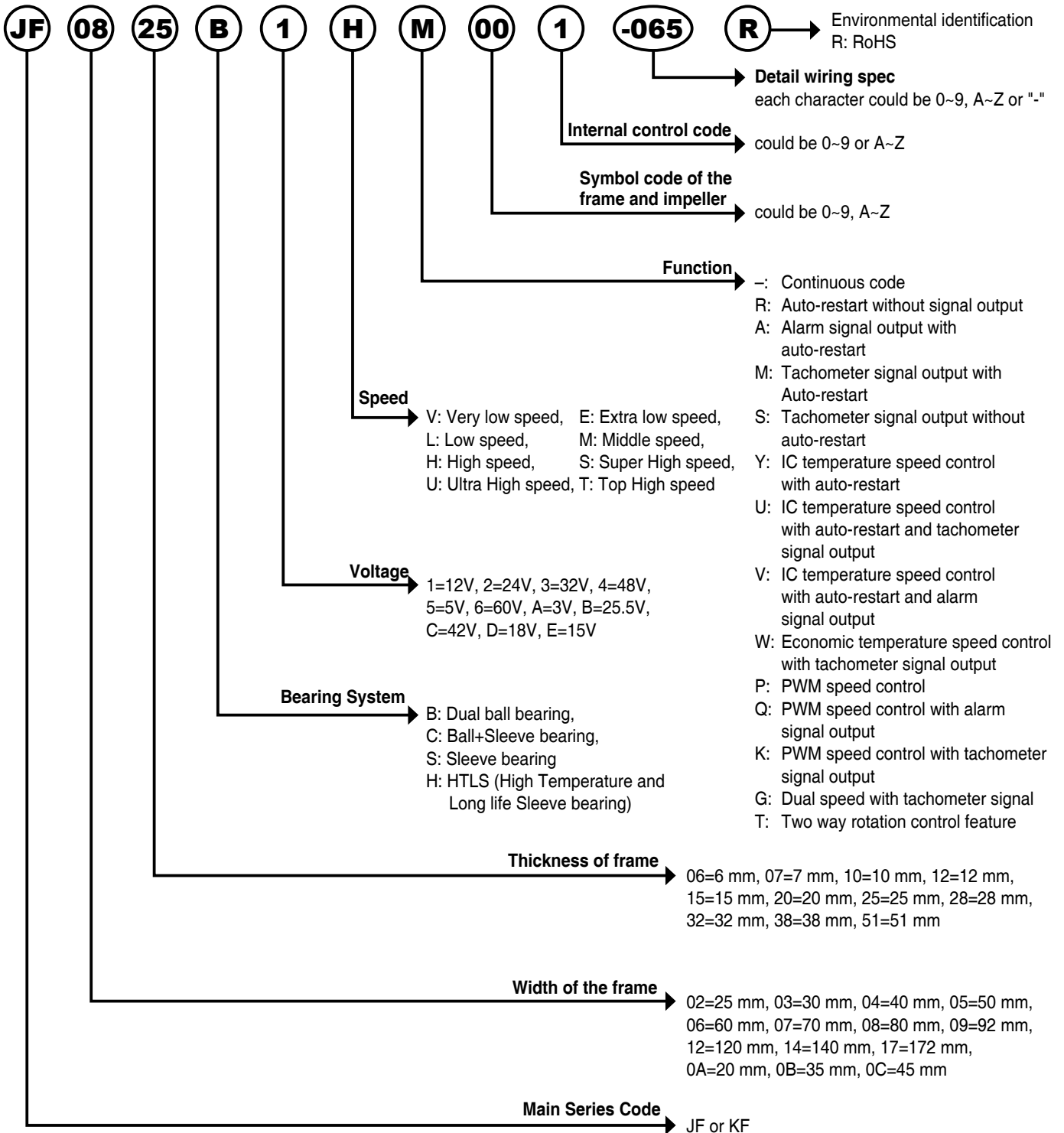

Reference List of Measure Unit

Air Flow Unit (風量單位)

CFM : Cubic Feet Per Minute (ft³/min ; 立方英尺/分)

CMM : Cubic Meter Per Minute (m³/min ; 立方公尺/分)

CMH : Cubic Meter Per Hour (m³/hr ; 立方公尺/小時)

Air Flow Unit Conversion (風量單位換算表)

CFM	CMM	CMH
1	0.0283	1.698
35.3	1	60
0.588	0.0167	1

Static Pressure Unit (靜壓單位)

Pa : Pascal (Pa = N/m² ; 牛頓/平方米)

mmAq : 1 mmAq = 1 mmH₂O

Static Pressure Unit Conversion (靜壓單位換算表)

Pa	mmH ₂ O	inch H ₂ O
1	0.10197	0.004017
9.80665	1	0.03939
249	25.4	1