

# Timing Circuit

The MC1455 monolithic timing circuit is a highly stable controller capable of producing accurate time delays or oscillation. Additional terminals are provided for triggering or resetting if desired. In the time delay mode, time is precisely controlled by one external resistor and capacitor. For astable operation as an oscillator, the free-running frequency and the duty cycle are both accurately controlled with two external resistors and one capacitor. The circuit may be triggered and reset on falling waveforms, and the output structure can source or sink up to 200 mA or drive MTTL circuits.

- Direct Replacement for NE555 Timers
- Timing from Microseconds through Hours
- Operates in Both Astable and Monostable Modes
- Adjustable Duty Cycle
- High Current Output Can Source or Sink 200 mA
- Output Can Drive MTTL
- Temperature Stability of 0.005% per °C
- Normally ON or Normally OFF Output

## MC1455, B

### TIMING CIRCUIT

#### SEMICONDUCTOR TECHNICAL DATA

**P1 SUFFIX**  
PLASTIC PACKAGE  
CASE 626

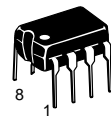

**D SUFFIX**  
PLASTIC PACKAGE  
CASE 751  
(SO-8)

**Figure 1. 22 Second Solid State Time Delay Relay Circuit**

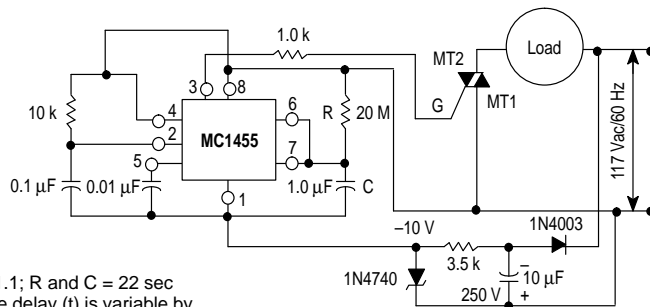

$t = 1.1RC$ ; R and C = 22 sec  
Time delay (t) is variable by  
changing R and C (see Figure 16).

**Figure 2. Representative Block Diagram**

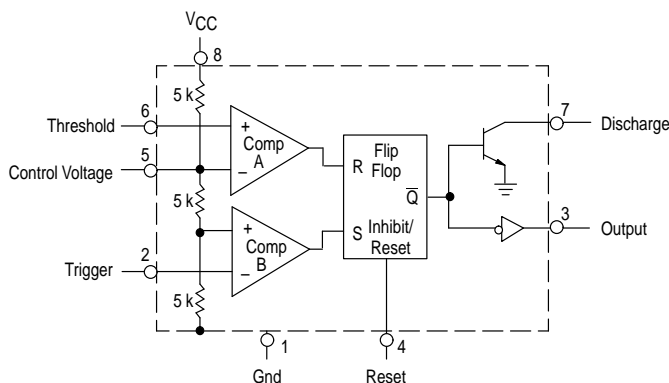

#### ORDERING INFORMATION

Device	Operating Temperature Range	Package
MC1455P1	$T_A = 0^\circ \text{ to } +70^\circ \text{C}$	Plastic DIP
MC1455D		SO-8
MC1455BD	$T_A = -40^\circ \text{ to } +85^\circ \text{C}$	SO-8
MC1455BP1		Plastic DIP

**Figure 3. General Test Circuit**

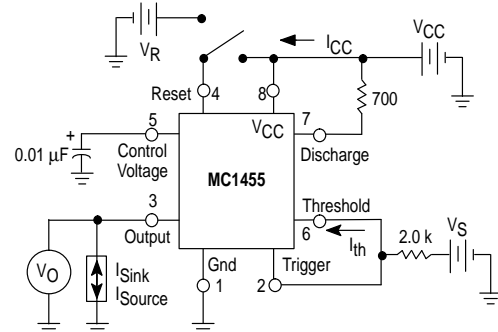

Test circuit for measuring DC parameters (to set output and measure parameters):

- When  $V_S \geq 2/3 V_{CC}$ ,  $V_O$  is low.
- When  $V_S \leq 1/3 V_{CC}$ ,  $V_O$  is high.
- When  $V_O$  is low, Pin 7 sinks current. To test for Reset, set  $V_O$  high, apply Reset voltage, and test for current flowing into Pin 7. When Reset is not in use, it should be tied to  $V_{CC}$ .

# MC1455, B

## MAXIMUM RATINGS (T<sub>A</sub> = +25°C, unless otherwise noted.)

Rating	Symbol	Value	Unit
Power Supply Voltage	V <sub>CC</sub>	+18	Vdc
Discharge Current (Pin 7)	I <sub>7</sub>	200	mA
Power Dissipation (Package Limitation)			
P1 Suffix, Plastic Package	P <sub>D</sub>	625	mW
Derate above T <sub>A</sub> = +25°C		5.0	mW/°C
D Suffix, Plastic Package	P <sub>D</sub>	625	mW
Derate above T <sub>A</sub> = +25°C		160	°C/W
Operating Temperature Range (Ambient)	T <sub>A</sub>		°C
MC1455B		-40 to +85	
MC1455		0 to +70	
Storage Temperature Range	T <sub>stg</sub>	-65 to +150	°C

## ELECTRICAL CHARACTERISTICS (T<sub>A</sub> = +25°C, V<sub>CC</sub> = +5.0 V to +15 V, unless otherwise noted.)

Characteristics	Symbol	Min	Typ	Max	Unit
Operating Supply Voltage Range	V <sub>CC</sub>	4.5	–	16	V
Supply Current	I <sub>CC</sub>				mA
V <sub>CC</sub> = 5.0 V, R <sub>L</sub> = ∞		–	3.0	6.0	
V <sub>CC</sub> = 15 V, R <sub>L</sub> = ∞, Low State (Note 1)		–	10	15	
Timing Error (R = 1.0 kΩ to 100 kΩ) (Note 2)					
Initial Accuracy C = 0.1 μF		–	1.0	–	%
Drift with Temperature		–	50	–	PPM/°C
Drift with Supply Voltage		–	0.1	–	%/V
Threshold Voltage/Supply Voltage	V <sub>th</sub> /V <sub>CC</sub>	–	2/3	–	
Trigger Voltage	V <sub>T</sub>				V
V <sub>CC</sub> = 15 V		–	5.0	–	
V <sub>CC</sub> = 5.0 V		–	1.67	–	
Trigger Current	I <sub>T</sub>	–	0.5	–	μA
Reset Voltage	V <sub>R</sub>	0.4	0.7	1.0	V
Reset Current	I <sub>R</sub>	–	0.1	–	mA
Threshold Current (Note 3)	I <sub>th</sub>	–	0.1	0.25	μA
Discharge Leakage Current (Pin 7)	I <sub>dischg</sub>	–	–	100	nA
Control Voltage Level	V <sub>CL</sub>				V
V <sub>CC</sub> = 15 V		9.0	10	11	
V <sub>CC</sub> = 5.0 V		2.6	3.33	4.0	
Output Voltage Low	V <sub>OL</sub>				V
I <sub>Sink</sub> = 10 mA (V <sub>CC</sub> = 15 V)		–	0.1	0.25	
I <sub>Sink</sub> = 50 mA (V <sub>CC</sub> = 15 V)		–	0.4	0.75	
I <sub>Sink</sub> = 100 mA (V <sub>CC</sub> = 15 V)		–	2.0	2.5	
I <sub>Sink</sub> = 200 mA (V <sub>CC</sub> = 15 V)		–	2.5	–	
I <sub>Sink</sub> = 8.0 mA (V <sub>CC</sub> = 5.0 V)		–	–	–	
I <sub>Sink</sub> = 5.0 mA (V <sub>CC</sub> = 5.0 V)		–	0.25	0.35	
Output Voltage High	V <sub>OH</sub>				V
V <sub>CC</sub> = 15 V (I <sub>Source</sub> = 200 mA)		–	12.5	–	
V <sub>CC</sub> = 15 V (I <sub>Source</sub> = 100 mA)		12.75	13.3	–	
V <sub>CC</sub> = 5.0 V (I <sub>Source</sub> = 100 mA)		2.75	3.3	–	
Rise Time Differential Output	t <sub>r</sub>	–	100	–	ns
Fall Time Differential Output	t <sub>f</sub>	–	100	–	ns

- NOTES:**
1. Supply current when output is high is typically 1.0 mA less.
  2. Tested at V<sub>CC</sub> = 5.0 V and V<sub>CC</sub> = 15 V Monostable mode.
  3. This will determine the maximum value of R<sub>A</sub> + R<sub>B</sub> for 15 V operation. The maximum total R = 20 MΩ.

Figure 4. Trigger Pulse Width

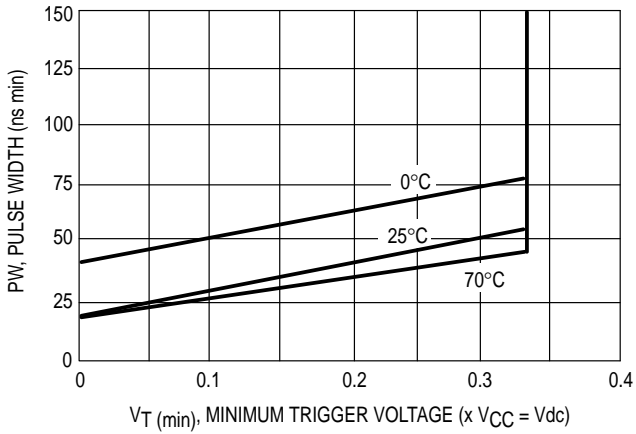

Figure 5. Supply Current

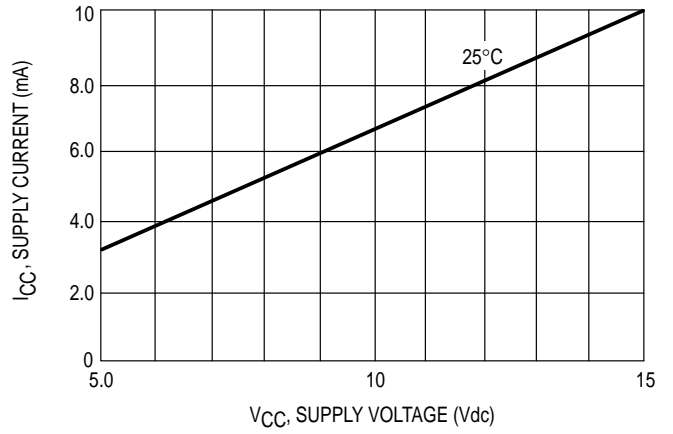

Figure 6. High Output Voltage

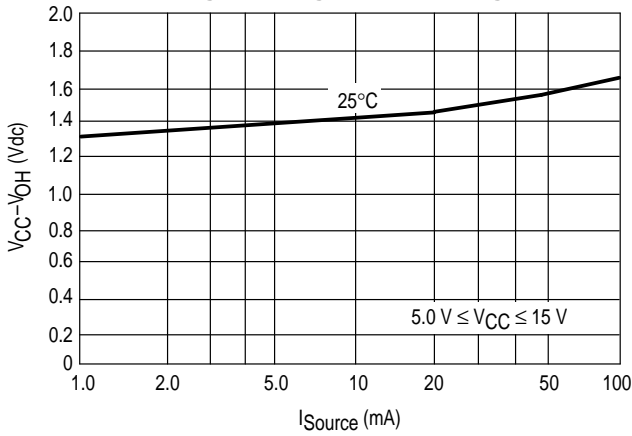

Figure 7. Low Output Voltage @ V<sub>CC</sub> = 5.0 V<sub>dC</sub>

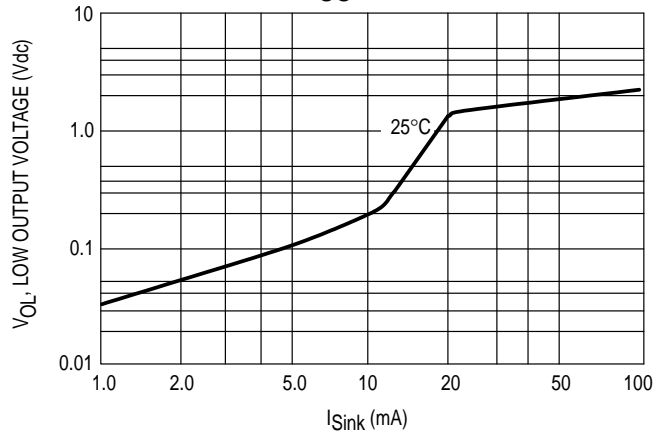

Figure 8. Low Output Voltage @ V<sub>CC</sub> = 10 V<sub>dC</sub>

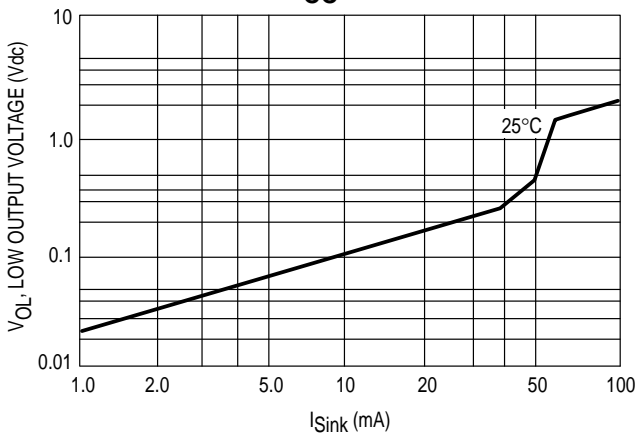

Figure 9. Low Output Voltage @ V<sub>CC</sub> = 15 V<sub>dC</sub>

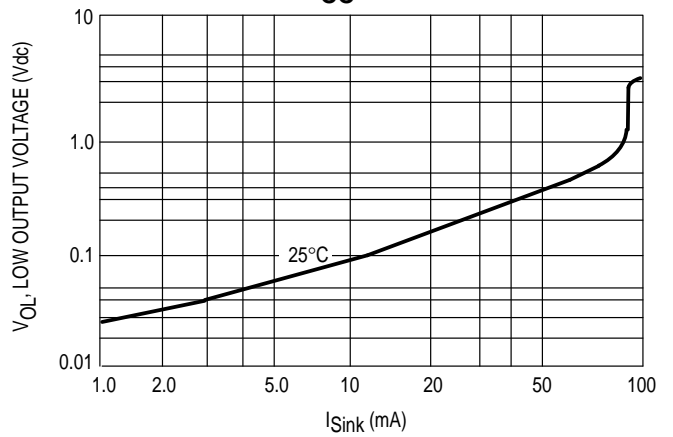

Figure 10. Delay Time versus Supply Voltage

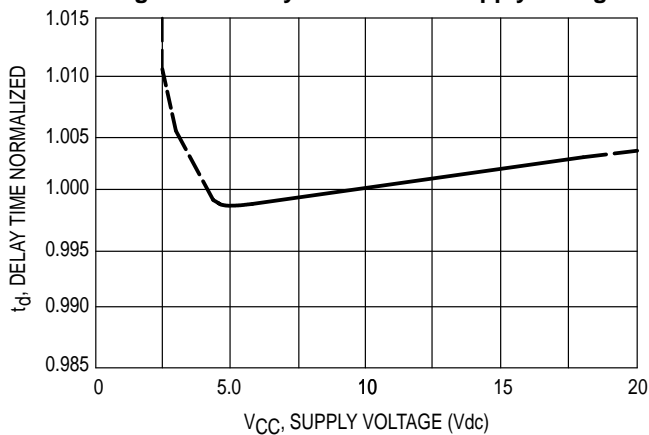

Figure 11. Delay Time versus Temperature

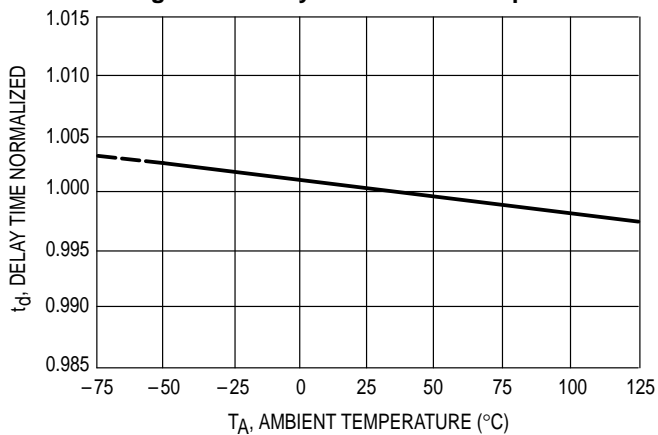

Figure 12. Propagation Delay versus Trigger Voltage

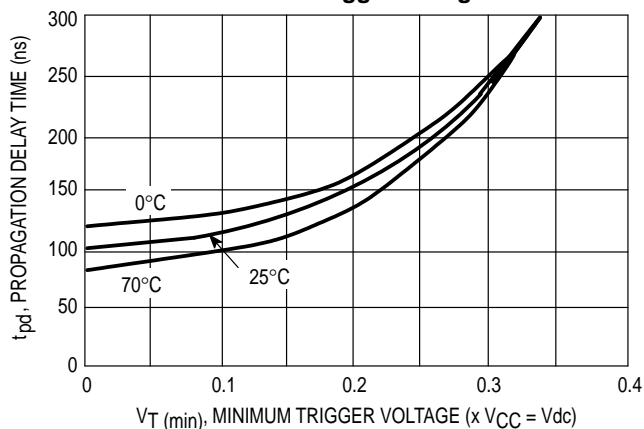
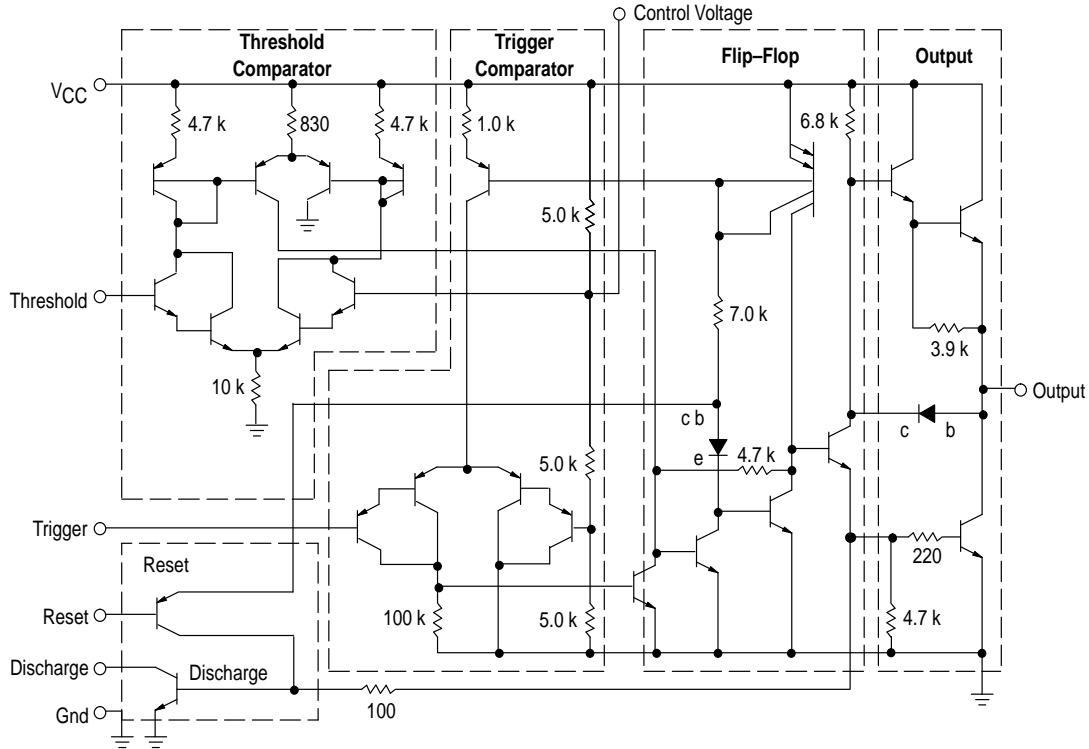

Figure 13. Representative Circuit Schematic



**GENERAL OPERATION**

The MC1455 is a monolithic timing circuit which uses an external resistor – capacitor network as its timing element. It can be used in both the monostable (one-shot) and astable modes with frequency and duty cycle controlled by the capacitor and resistor values. While the timing is dependent upon the external passive components, the monolithic circuit provides the starting circuit, voltage comparison and other functions needed for a complete timing circuit. Internal to the integrated circuit are two comparators, one for the input signal and the other for capacitor voltage; also a flip-flop and digital output are included. The comparator reference voltages are always a fixed ratio of the supply voltage thus providing output timing independent of supply voltage.

**Monostable Mode**

In the monostable mode, a capacitor and a single resistor are used for the timing network. Both the threshold terminal and the discharge transistor terminal are connected together in this mode (refer to circuit in Figure 14). When the input voltage to the trigger comparator falls below  $1/3 V_{CC}$ , the comparator output triggers the flip-flop so that its output sets low. This turns the capacitor discharge transistor “off” and drives the digital output to the high state. This condition allows the capacitor to charge at an exponential rate which is set by the RC time constant. When the capacitor voltage reaches  $2/3 V_{CC}$ , the threshold comparator resets the flip-flop. This action discharges the timing capacitor and returns the digital output to the low state. Once the flip-flop has been triggered by an input signal, it cannot be retriggered

until the present timing period has been completed. The time that the output is high is given by the equation  $t = 1.1 R_A C$ . Various combinations of R and C and their associated times are shown in Figure 16. The trigger pulse width must be less than the timing period.

A reset pin is provided to discharge the capacitor, thus interrupting the timing cycle. As long as the reset pin is low, the capacitor discharge transistor is turned “on” and prevents the capacitor from charging. While the reset voltage is applied the digital output will remain the same. The reset pin should be tied to the supply voltage when not in use.

Figure 14. Monostable Circuit

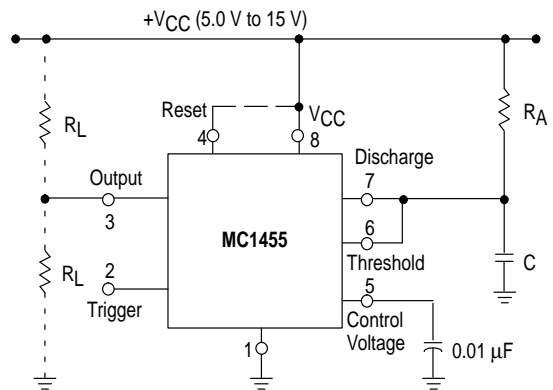

Figure 15. Monostable Waveforms

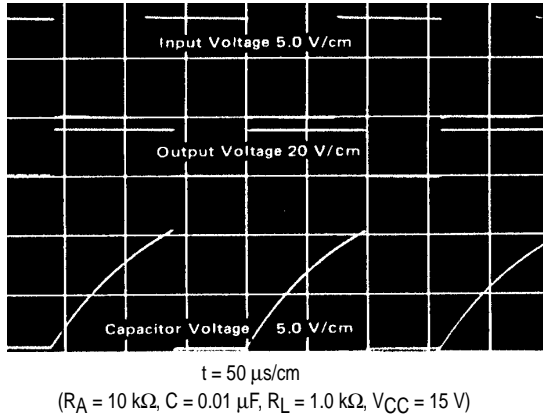

Figure 16. Time Delay

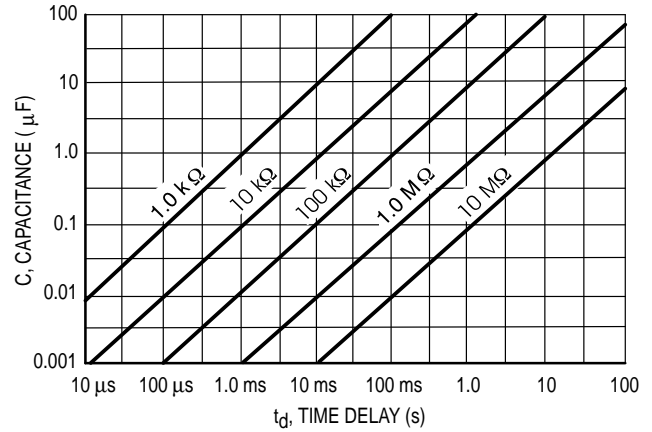

Figure 17. Astable Circuit

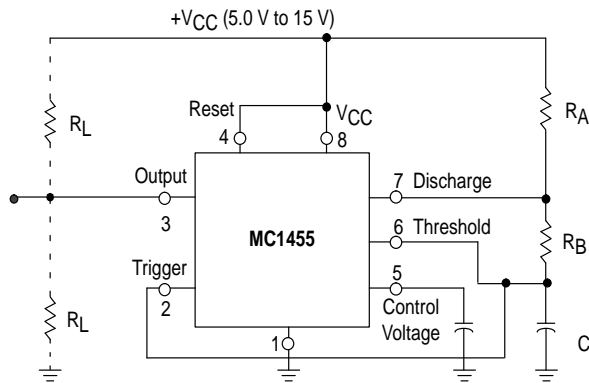
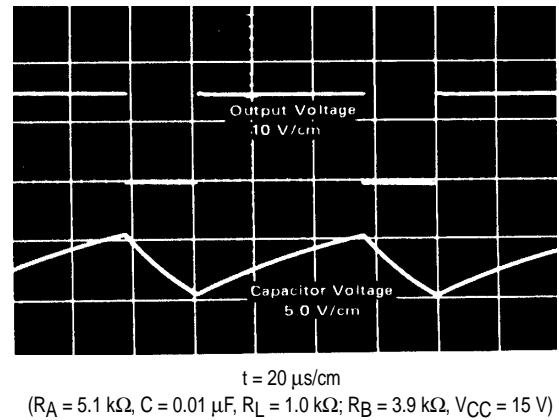

Figure 18. Astable Waveforms



**Astable Mode**

In the astable mode the timer is connected so that it will retrigger itself and cause the capacitor voltage to oscillate between  $1/3 V_{CC}$  and  $2/3 V_{CC}$ . See Figure 17.

The external capacitor charges to  $2/3 V_{CC}$  through  $R_A$  and  $R_B$  and discharges to  $1/3 V_{CC}$  through  $R_B$ . By varying the ratio of these resistors the duty cycle can be varied. The charge and discharge times are independent of the supply voltage.

The charge time (output high) is given by:

$$t_1 = 0.695 (R_A + R_B) C$$

The discharge time (output low) is given by:

$$t_2 = 0.695 (R_B) C$$

Thus the total period is given by:

$$T = t_1 + t_2 = 0.695 (R_A + 2R_B) C$$

The frequency of oscillation is then:  $f = \frac{1}{T} = \frac{1.44}{(R_A + 2R_B) C}$

and may be easily found as shown in Figure 19.

The duty cycle is given by:  $DC = \frac{R_B}{R_A + 2R_B}$

To obtain the maximum duty cycle  $R_A$  must be as small as possible; but it must also be large enough to limit the

discharge current (Pin 7 current) within the maximum rating of the discharge transistor (200 mA).

The minimum value of  $R_A$  is given by:

$$R_A \geq \frac{V_{CC} (V_{dc})}{I_7 (A)} \geq \frac{V_{CC} (V_{dc})}{0.2}$$

Figure 19. Free Running Frequency

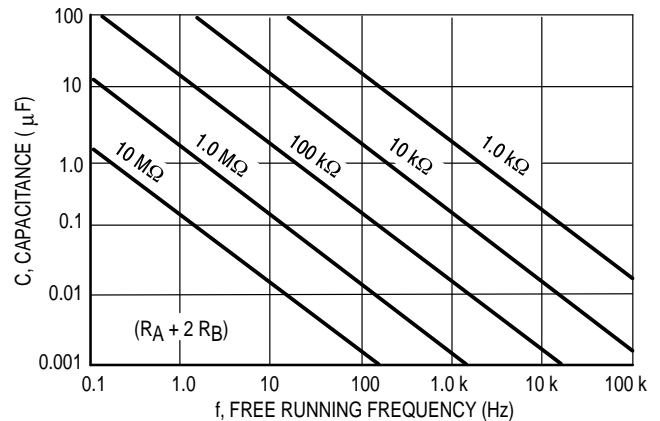

# MC1455, B

## APPLICATIONS INFORMATION

### Linear Voltage Ramp

In the monostable mode, the resistor can be replaced by a constant current source to provide a linear ramp voltage. The capacitor still charges from 0  $V_{CC}$  to  $2/3 V_{CC}$ . The linear ramp time is given by:

$$t = \frac{2}{3} \frac{V_{CC}}{I}, \text{ where } I = \frac{V_{CC} - V_B - V_{BE}}{R_E}$$

If  $V_B$  is much larger than  $V_{BE}$ , then  $t$  can be made independent of  $V_{CC}$ .

### Missing Pulse Detector

The timer can be used to produce an output when an input pulse fails to occur within the delay of the timer. To accomplish this, set the time delay to be slightly longer than the time between successive input pulses. The timing cycle is then continuously reset by the input pulse train until a change in frequency or a missing pulse allows completion of the timing cycle, causing a change in the output level.

Figure 20. Linear Voltage Sweep Circuit

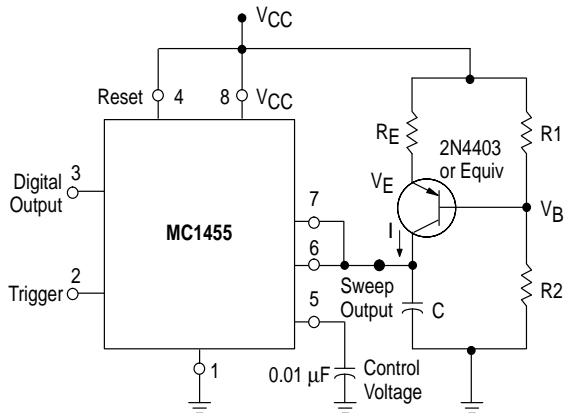

Figure 21. Missing Pulse Detector

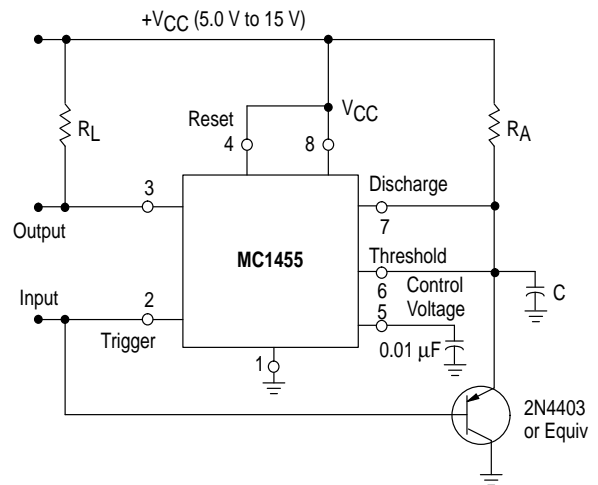
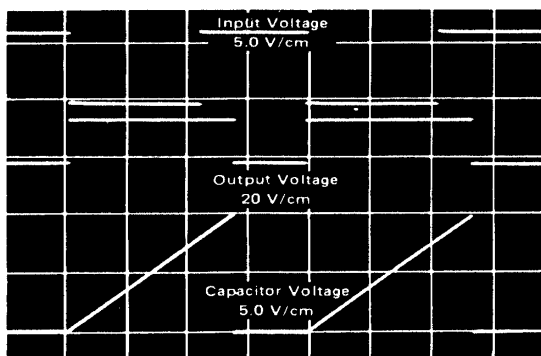

Figure 22. Linear Voltage Ramp Waveforms



$t = 100 \mu\text{s/cm}$

( $R_E = 10 \text{ k}\Omega$ ,  $R_2 = 100 \text{ k}\Omega$ ,  $R_1 = 39 \text{ k}\Omega$ ,  $C = 0.01 \mu\text{F}$ ,  $V_{CC} = 15 \text{ V}$ )

Figure 23. Missing Pulse Detector Waveforms

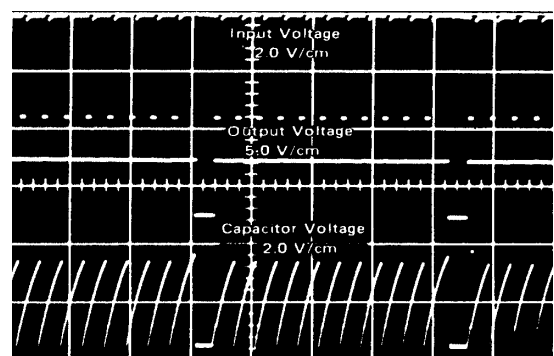

$t = 500 \mu\text{s/cm}$

( $R_A = 2.0 \text{ k}\Omega$ ,  $R_L = 1.0 \text{ k}\Omega$ ,  $C = 0.01 \mu\text{F}$ ,  $V_{CC} = 15 \text{ V}$ )

**Pulse Width Modulation**

If the timer is triggered with a continuous pulse train in the monostable mode of operation, the charge time of the capacitor can be varied by changing the control voltage at Pin 5. In this manner, the output pulse width can be modulated by applying a modulating signal that controls the threshold voltage.

**Figure 24. Pulse Width Modulator**

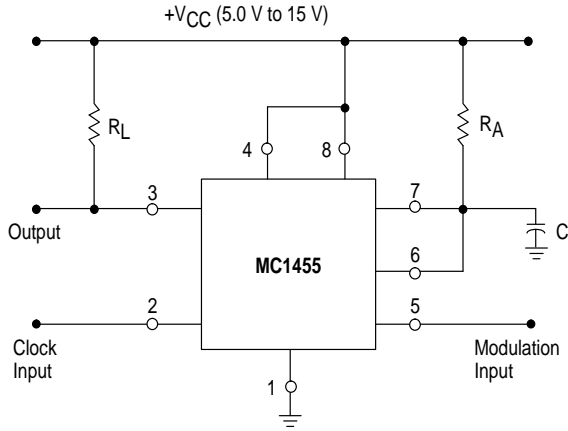

**Figure 25. Pulse Width Modulation Waveforms**

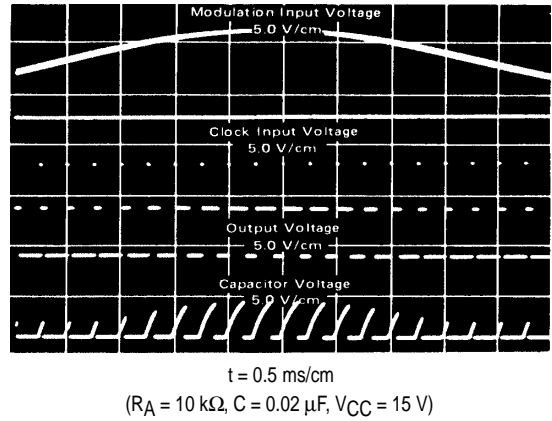

**Test Sequences**

Several timers can be connected to drive each other for sequential timing. An example is shown in Figure 26 where the sequence is started by triggering the first timer which runs for 10 ms. The output then switches low momentarily and starts the second timer which runs for 50 ms and so forth.

**Figure 26. Sequential Timer**

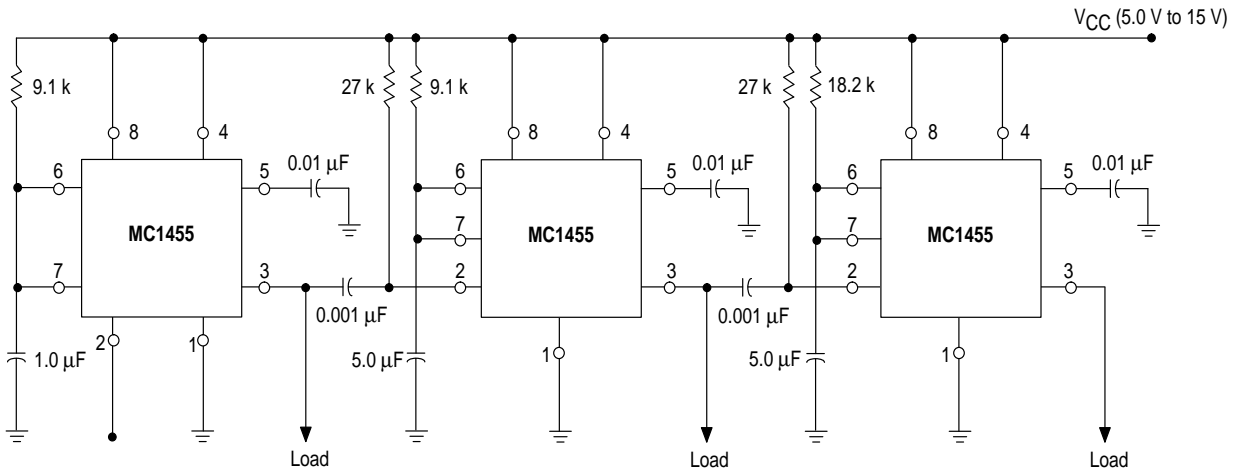



# MC1455, B

## OUTLINE DIMENSIONS

P1 SUFFIX  
 PLASTIC PACKAGE  
 CASE 626-05  
 ISSUE K

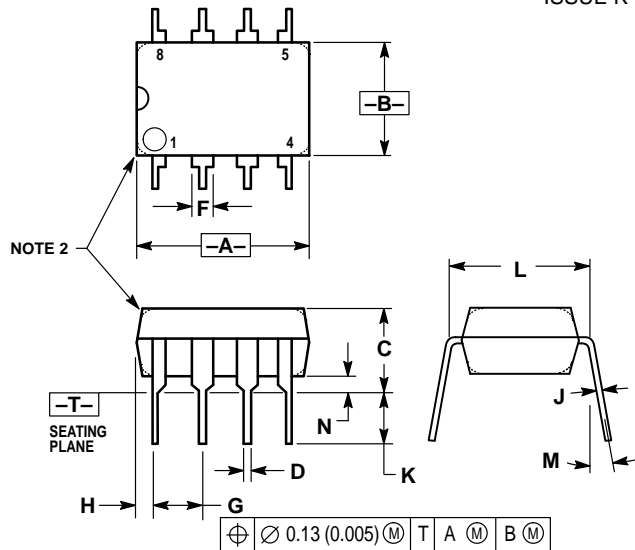

- NOTES:
1. DIMENSION L TO CENTER OF LEAD WHEN FORMED PARALLEL.
  2. PACKAGE CONTOUR OPTIONAL (ROUND OR SQUARE CORNERS).
  3. DIMENSIONING AND TOLERANCING PER ANSI Y14.5M, 1982.

DIM	MILLIMETERS		INCHES	
	MIN	MAX	MIN	MAX
A	9.40	10.16	0.370	0.400
B	6.10	6.60	0.240	0.260
C	3.94	4.45	0.155	0.175
D	0.38	0.51	0.015	0.020
F	1.02	1.78	0.040	0.070
G	2.54 BSC		0.100 BSC	
H	0.76	1.27	0.030	0.050
J	0.20	0.30	0.008	0.012
K	2.92	3.43	0.115	0.135
L	7.62 BSC		0.300 BSC	
M	—		10°	
N	0.76	1.01	0.030	0.040

# MC1455, B

## OUTLINE DIMENSIONS

**D SUFFIX**  
 PLASTIC PACKAGE  
 CASE 751-06  
 (SO-8)  
 ISSUE T

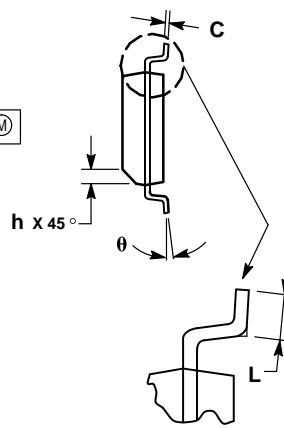
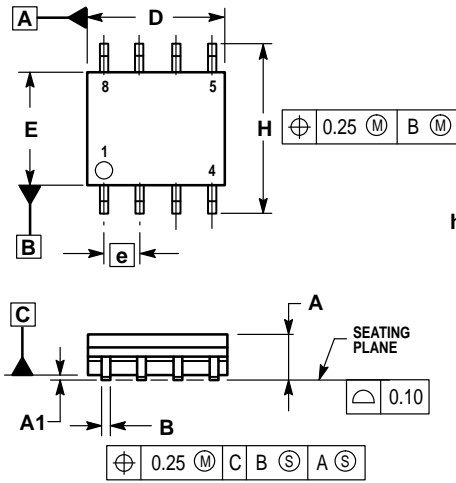

**NOTES:**

1. DIMENSIONING AND TOLERANCING PER ASME Y14.5M, 1994.
2. DIMENSIONS ARE IN MILLIMETER.
3. DIMENSION D AND E DO NOT INCLUDE MOLD PROTRUSION.
4. MAXIMUM MOLD PROTRUSION 0.15 PER SIDE.
5. DIMENSION B DOES NOT INCLUDE DAMBAR PROTRUSION. ALLOWABLE DAMBAR PROTRUSION SHALL BE 0.127 TOTAL IN EXCESS OF THE B DIMENSION AT MAXIMUM MATERIAL CONDITION.

DIM	MILLIMETERS	
	MIN	MAX
A	1.35	1.75
A1	0.10	0.25
B	0.35	0.49
C	0.19	0.25
D	4.80	5.00
E	3.80	4.00
e	1.27	BSC
H	5.80	6.20
h	0.25	0.50
L	0.40	1.25
θ	0°	7°

MC1455, B

# NOTES

Motorola reserves the right to make changes without further notice to any products herein. Motorola makes no warranty, representation or guarantee regarding the suitability of its products for any particular purpose, nor does Motorola assume any liability arising out of the application or use of any product or circuit, and specifically disclaims any and all liability, including without limitation consequential or incidental damages. "Typical" parameters which may be provided in Motorola data sheets and/or specifications can and do vary in different applications and actual performance may vary over time. All operating parameters, including "Typicals" must be validated for each customer application by customer's technical experts. Motorola does not convey any license under its patent rights nor the rights of others. Motorola products are not designed, intended, or authorized for use as components in systems intended for surgical implant into the body, or other applications intended to support or sustain life, or for any other application in which the failure of the Motorola product could create a situation where personal injury or death may occur. Should Buyer purchase or use Motorola products for any such unintended or unauthorized application, Buyer shall indemnify and hold Motorola and its officers, employees, subsidiaries, affiliates, and distributors harmless against all claims, costs, damages, and expenses, and reasonable attorney fees arising out of, directly or indirectly, any claim of personal injury or death associated with such unintended or unauthorized use, even if such claim alleges that Motorola was negligent regarding the design or manufacture of the part. Motorola and  are registered trademarks of Motorola, Inc. Motorola, Inc. is an Equal Opportunity/Affirmative Action Employer.

Mfax is a trademark of Motorola, Inc.

**How to reach us:**

**USA/EUROPE/Locations Not Listed:** Motorola Literature Distribution;  
P.O. Box 5405, Denver, Colorado 80217. 1-303-675-2140 or 1-800-441-2447

**JAPAN:** Motorola Japan Ltd.; SPD, Strategic Planning Office, 141,  
4-32-1 Nishi-Gotanda, Shinagawa-ku, Tokyo, Japan. 81-3-5487-8488

**Customer Focus Center: 1-800-521-6274**

**Mfax™:** RMFAX0@email.sps.mot.com – TOUCHTONE 1-602-244-6609  
Motorola Fax Back System – US & Canada ONLY 1-800-774-1848  
– http://sps.motorola.com/mfax/

**ASIA/PACIFIC:** Motorola Semiconductors H.K. Ltd.; Silicon Harbour Centre,  
2, Dai King Street, Tai Po Industrial Estate, Tai Po, N.T., Hong Kong.  
852-26668334

**HOME PAGE:** <http://motorola.com/sps/>



**MOTOROLA**

