

# μA796<sup>✓</sup>

## DOUBLE-BALANCED MODULATOR/DEMODULATOR

FAIRCHILD LINEAR INTEGRATED CIRCUIT

**GENERAL DESCRIPTION** — The μA796 is a monolithic Double-Balanced Modulator/Demodulator using the Fairchild Planar\* epitaxial process. This circuit produces an output voltage which is the product of an input voltage (signal) and a switching function (carrier). Communications applications include modulation and demodulation of AM, SSB, DSB, FSK, FM and phase encoded signals. Signal conditioning techniques possible include frequency doubling and halving, linear mixing and chopping, with additional uses as phase detectors in phase locked loops and as differentiators in NRZ and phase encoded digital tape and disk memories.

- EXCELLENT CARRIER SUPPRESSION
- LOW OFFSETS AND DRIFT
- FULLY BALANCED INPUTS AND OUTPUT
- USEFUL TO 100 MHz
- WIDE RANGE OF APPLICATION

### ABSOLUTE MAXIMUM RATINGS

Internal Power Dissipation (Note 1)	500 mW
Applied Voltage (Note 2)	30 V
Differential Input Signal ( $V_7 - V_8$ )	±5.0 V
Differential Input Signal ( $V_4 - V_1$ )	±(5 + I <sub>5</sub> R <sub>θ</sub> ) V
Input Signal ( $V_2 - V_1, V_3 - V_4$ )	5.0 V
Bias Current (I <sub>5</sub> )	12 mA
Storage Temperature Range	-65°C to +150°C
Operating Temperature Range (μA796)	-55°C to +125°C
Operating Temperature Range (μA796C)	0°C to +70°C
Pin Temperature (Soldering, 10 s)	300°C

### CONNECTION DIAGRAMS

#### 10-PIN METAL CAN

(TOP VIEW)  
PACKAGE OUTLINE 5Q  
PACKAGE CODE H

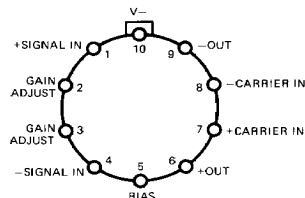

**ORDER INFORMATION**

<b>TYPE</b>	<b>PART NO.</b>
μA796	μA796HM
μA796C	μA796HC

### 14-PIN DIP

(TOP VIEW)  
PACKAGE OUTLINE 9A  
PACKAGE CODE P

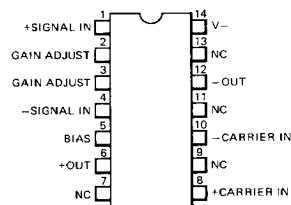

**ORDER INFORMATION**

<b>TYPE</b>	<b>PART NO.</b>
μA796C	μA796PC <sup>✓</sup>

### EQUIVALENT CIRCUIT

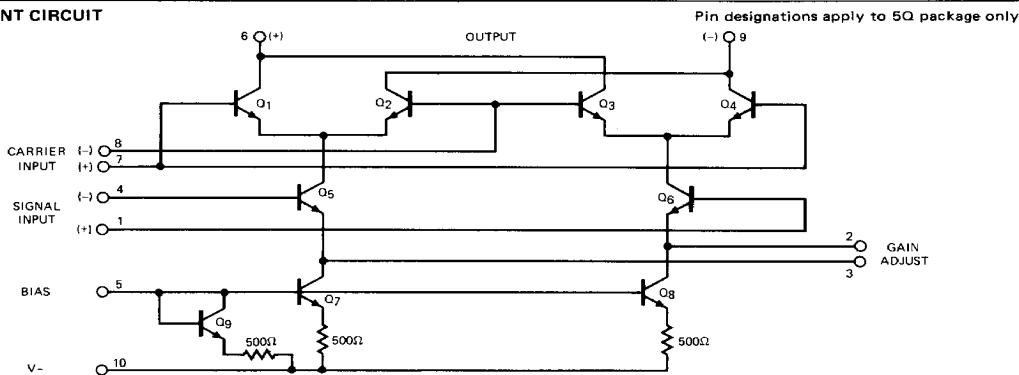

Notes on following pages.

\*Planar is a patented Fairchild process.

$\mu$ A796

**ELECTRICAL CHARACTERISTICS:**  $T_A = 25^\circ\text{C}$ , Figure 1 unless otherwise specified.

CHARACTERISTICS	CONDITIONS	MIN	TYP	MAX	UNITS
Carrier Feedthrough	$V_C = 60$ mV (rms) sine wave $f_C = 1.0$ kHz, offset adjusted		40		$\mu$ V (rms)
	$V_C = 60$ mV (rms) sine wave $f_C = 10$ MHz, offset adjusted		140		$\mu$ V (rms)
	$V_C = 300$ mV <sub>pp</sub> square wave $f_C = 1.0$ kHz, offset adjusted $V_C = 300$ mV <sub>pp</sub> square wave $f_C = 1.0$ kHz, offset not adjusted		0.04 20	0.2 100	mV (rms) mV (rms)
Carrier Suppression	$f_S = 10$ kHz, 300 mV (rms) $f_C = 500$ kHz, 60 mV (rms) sine wave offset adjusted	50	65		dB
	$f_S = 10$ kHz, 300 mV (rms) $f_C = 10$ MHz, 60 mV (rms) sine wave offset adjusted		50		dB
Transadmittance Bandwidth	$R_L = 50\Omega$ Carrier Input Port, $V_C = 60$ mV (rms) sine wave $f_S = 1.0$ kHz, 300 mV (rms) sine wave		300		MHz
	Signal Input Port, $V_S = 300$ mV (rms) sine wave $V_7 - V_8 = 0.5$ V dc		80		MHz
Voltage Gain, Signal Channel	$V_S = 100$ mV (rms), $f = 1.0$ kHz $V_7 - V_8 = 0.5$ V dc	2.5	3.5		V/V
Input Resistance, Signal Port	$f = 5.0$ MHz $V_7 - V_8 = 0.5$ V dc		200		k $\Omega$
Input Capacitance, Signal Port	$f = 5.0$ MHz $V_7 - V_8 = 0.5$ V dc		2.0		pF
Single Ended Output Resistance	$f = 10$ MHz		40		k $\Omega$
Single Ended Output Capacitance	$f = 10$ MHz		5.0		pF
Input Bias Current	$(I_1 + I_4)/2$		12	25	$\mu$ A
Input Bias Current	$(I_7 + I_8)/2$		12	25	$\mu$ A
Input Offset Current	$(I_1 - I_4)$		0.7	5.0	$\mu$ A
Input Offset Current	$(I_7 - I_8)$		0.7	5.0	$\mu$ A
Average Temperature Coefficient of Input Offset Current	$(-55^\circ\text{C} < T_A < +125^\circ\text{C})$		2.0		nA/ $^\circ\text{C}$
Output Offset Current	$(I_6 - I_9)$		14	50	$\mu$ A
Average Temperature Coefficient of Output Offset Current	$(-55^\circ\text{C} < T_A < +125^\circ\text{C})$		90		nA/ $^\circ\text{C}$
Signal Port Common Mode Input Voltage Range	$f_S = 1.0$ kHz		5.0		V <sub>p-p</sub>
Signal Port Common Mode Rejection Ratio	$V_7 - V_8 = 0.5$ V dc		-85		dB
Common Mode Quiescent Output Voltage			8.0		V <sub>dc</sub>
Differential Output Swing Capability			8.0		V <sub>D-P</sub>
Positive Supply Current	$(I_6 + I_9)$		2.0	3.0	mA
Negative Supply Current	$(I_{10})$		3.0	4.0	mA
Power Dissipation			33		mW

NOTES: 4

1. Rating applies to ambient temperature up to  $70^\circ\text{C}$ . Above  $70^\circ\text{C}$  ambient derate linearly at  $6.3$  mW/ $^\circ\text{C}$ .
2. Voltage applied between 6-7, 8-1, 9-7, 9-8, 7-4, 7-1, 8-4, 6-8, 2-5, 3-5.

4

FAIRCHILD •  $\mu$ A796

$\mu$ A796C

ELECTRICAL CHARACTERISTICS:  $T_A = 25^\circ\text{C}$ , Figure 1 unless otherwise specified

CHARACTERISTICS	CONDITIONS (Pin designations apply to metal can package only)	MIN	TYP	MAX	UNITS
Carrier Feedthrough	$V_C = 60\text{ mV (rms) sine wave}$ $f_C = 1.0\text{ kHz, offset adjusted}$		40		$\mu\text{V rms}$
	$V_C = 60\text{ mV (rms) sine wave}$ $f_C = 10\text{ MHz, offset adjusted}$		140		$\mu\text{V rms}$
	$V_C = 300\text{ mV}_{pp}\text{ square wave}$ $f_C = 1.0\text{ kHz, offset adjusted}$		0.04	0.2	mV rms
	$V_C = 300\text{ mV}_{pp}\text{ square wave}$ $f_C = 1.0\text{ kHz, offset not adjusted}$		20	150	mV rms
Carrier Suppression	$f_S = 10\text{ kHz, 300 mV (rms)}$ $f_C = 500\text{ kHz, 60 mV (rms) sine wave}$ offset adjusted	50	65		dB
	$f_S = 10\text{ kHz, 300 mV (rms)}$ $f_C = 10\text{ MHz, 60 mV (rms) sine wave}$ offset adjusted		50		dB
Transadmittance Bandwidth	$R_L = 50\Omega$ Carrier Input Port, $V_C = 60\text{ mV (rms) sine wave}$ $f_S = 1.0\text{ kHz, 300 mV (rms) sine wave}$		300		MHz
	Signal Input Port, $V_S = 300\text{ mV (rms) sine wave}$ $V_7 - V_8 = 0.5\text{ V dc}$		80		MHz
Voltage Gain, Signal Channel	$V_S = 100\text{ mV (rms), } f = 1.0\text{ kHz}$ $V_7 - V_8 = 0.5\text{ V dc}$	2.5	3.5		V/V
Input Resistance, Signal Port	$f = 5.0\text{ MHz}$ $V_7 - V_8 = 0.5\text{ V dc}$		200		$\text{k}\Omega$
Input Capacitance, Signal Port	$f = 5.0\text{ MHz}$ $V_7 - V_8 = 0.5\text{ V dc}$		2.0		pF
Single Ended Output Resistance	$f = 10\text{ MHz}$		40		$\text{k}\Omega$
Single Ended Output Capacitance	$f = 10\text{ MHz}$		5.0		pF
Input Bias Current	$(I_1 + I_4)/2$		12	30	$\mu\text{A}$
	$(I_7 + I_8)/2$		12	30	$\mu\text{A}$
Input Offset Current	$(I_1 - I_4)$		0.7	5.0	$\mu\text{A}$
	$(I_7 - I_8)$		0.7	5.0	$\mu\text{A}$
Average Temperature Coefficient of Input Offset Current	$0^\circ\text{C} \leq T_A \leq +70^\circ\text{C}$		2.0		$\text{nA}/^\circ\text{C}$
Output Offset Current	$(I_6 - I_9)$		14	60	$\mu\text{A}$
Average Temperature Coefficient of Output Offset Current	$0^\circ\text{C} < T_A < +70^\circ\text{C}$		90		$\text{nA}/^\circ\text{C}$
Signal Port Common Mode Input Voltage Range	$f_S = 1.0\text{ kHz}$		5.0		$V_{P-P}$
Signal Port Common Mode Rejection Ratio	$V_7 - V_8 = 0.5\text{ V dc}$		-85		dB
Common Mode Quiescent Output Voltage			8.0		Vdc
Differential Output Swing Capability			8.0		$V_{P-P}$
Positive Supply Current	$(I_6 + I_9)$		2.0	3.0	mA
Negative Supply Current	$(I_{10})$		3.0	4.0	mA
Power Dissipation			33		mW

NOTES

1. Rating applies to ambient temperatures up to  $70^\circ\text{C}$ .
2. Voltage applied between pins 6-7, 8-1, 9-7, 7-4, 7-1, 8-4, 6-8, 2-5, 3-5.

TYPICAL PERFORMANCE CURVES FOR  $\mu A796$

CARRIER SUPPRESSION AS A FUNCTION OF CARRIER INPUT LEVEL

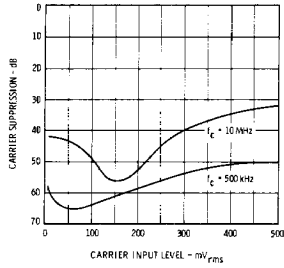

CARRIER SUPPRESSION AS A FUNCTION OF FREQUENCY

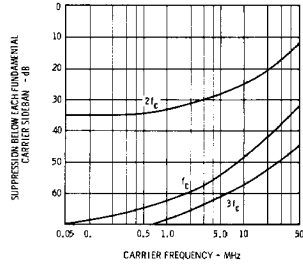

CARRIER FEEDTHROUGH AS A FUNCTION OF FREQUENCY

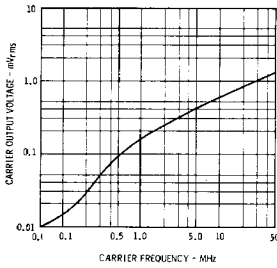

SIGNAL-PORT FREQUENCY RESPONSE

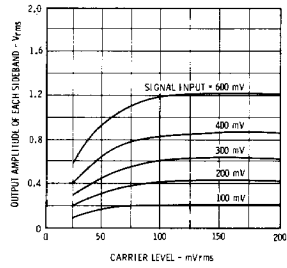

SIDEBAND OUTPUT AS A FUNCTION OF CARRIER LEVELS

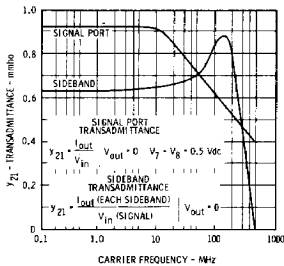

SIDEBAND AND SIGNAL PORT TRANSMITTANCES AS A FUNCTION OF FREQUENCY

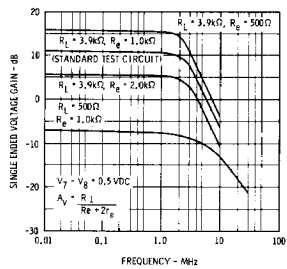

TYPICAL APPLICATIONS

TYPICAL MODULATOR CIRCUIT

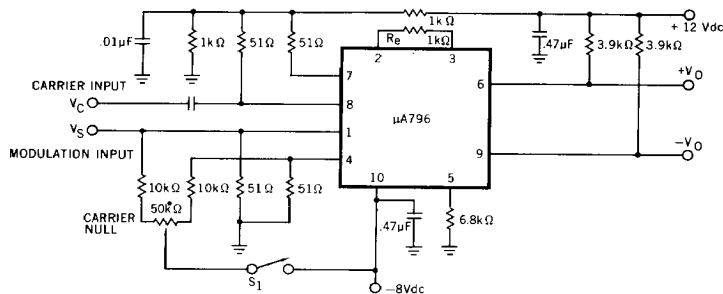

Note:  $S_1$  is closed for "adjusted" measurements.

Fig. 1

PRODUCT DETECTOR

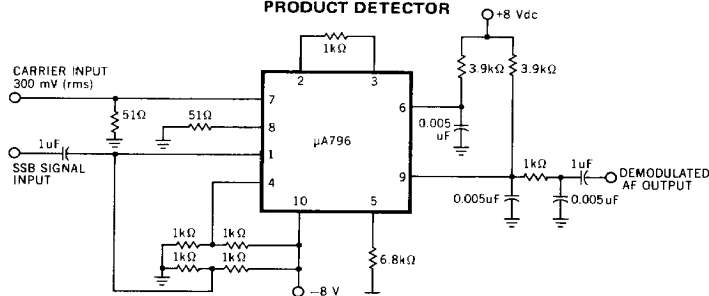

This figure shows the  $\mu$ A796 used as a single sideband (SSB) suppressed carrier demodulator (product detector). The carrier signal is applied to the carrier input port with sufficient amplitude for switching operation. A carrier input level of 300 mV(rms) is optimum. The composite SSB signal is applied to the signal input port with an amplitude of 5.0 to 500 mV(rms). All output signal components except the desired demodulated audio are filtered out, so that an offset adjustment is not required. This circuit may also be used as an AM detector by applying composite and carrier signals in the same manner as described for product detector operation.

Fig. 2

FREQUENCY DOUBLER

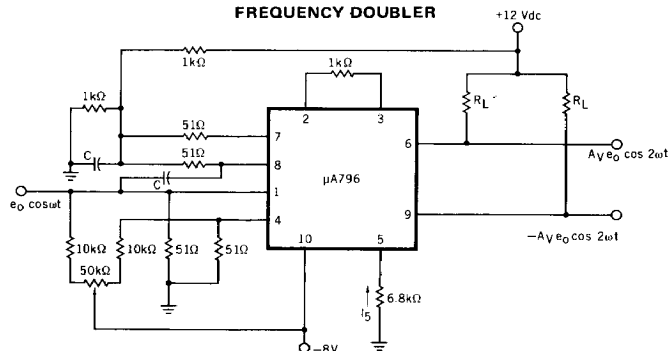

The frequency doubler circuit shown will double low-level signals with low distortion. The value of C should be chosen for low reactance at the operating frequency.

Signal level at the carrier input must be less than 25 mV peak to maintain operation in the linear region of the switching differential amplifier. Levels to 50 mV peak may be used with some distortion of the output waveform. If a larger input signal is available a resistive divider may be used at the carrier input, with full signal applied to the signal input.

Fig. 3